

FUTURE FORCES FORUM

EXHIBITOR HANDBOOK

- [When & Where](#)
- [Travel Information](#)
- [Accommodation](#)
- [General Instructions for Exhibitors](#)
- [Instructions for Exhibitors of Military or Security Material, Weapons and Ammunition](#)
- [Licences - Information for Military and Security Material Exhibitors](#)
- [General Cargo Shipping Instructions](#)
- [Contacts](#)
- [Order Forms](#)

www.future-forces-forum.org



WHEN & WHERE

WHEN

17 - 19 October 2018	
Wednesday 17 October	9.30 - 17.00
Thursday 18 October	9.00 - 17.00
Friday 19 October	9.00 - 16.00

WHERE

PVA EXPO PRAHA	
Beranových 667 190 00 Prague 9 – Letňany Czech Republic	
GPS Loc:	50° 7' 41.662" N 14° 30' 51.679" E



FAIRGROUND PLAN

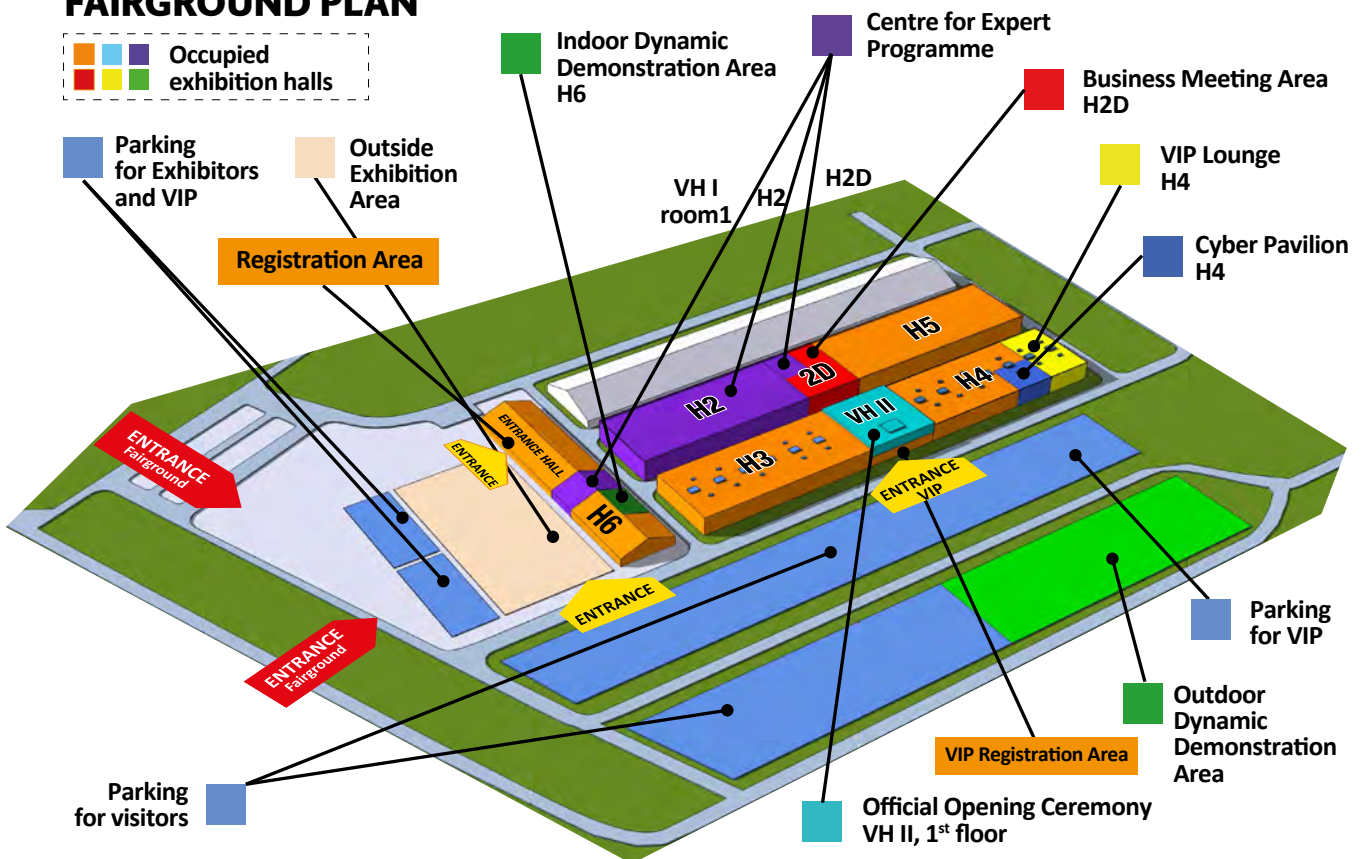



TRAVEL INFORMATION



Metro (Underground)



The most convenient transport to PVA EXPO is metro line C (red) to [station Letňany](#) (terminal station) and 5 minute walk.



BUS



There are regular bus lines operating to stops nearby PVA EXPO: [Výstaviště Letňany](#) bus stop or [Letňany](#) bus stop/metro station.



Find a Connection

To find a suitable connection you can use the [online application](#) for direct connections and connections with transfers between entered stops or locations.

Prague Public Transit Company

More information about public transport in Prague is available at www.dpp.cz/en.

- [Transport around Prague](#)
- [Prague transport maps](#)
- [Fares in Prague and periphery areas](#)
- [Mobile App](#)



TAXI

We recommend using our partner company **HALOTAXI**. **To travel for guaranteed rates please order the journey as „FUTURE FORCES“.**

Payment is available in cash in CZK or EUR.

Order your journey by phone at **+420 244 114 411**

Overview of guaranteed prices for selected routes:



From	To	CZK	EUR
Václav Havel Airport	Václavské náměstí (Wenceslas Square)	700	28
Václav Havel Airport	Hotel Diplomat 4*	540	22
Václav Havel Airport	Hotel International 4*	540	22
Václav Havel Airport	Hotel DUO 4*	900	36
Václav Havel Airport	PVA EXPO PRAHA	950	38
Hotel Diplomat 4*	PVA EXPO PRAHA	620	25
Hotel International 4*	PVA EXPO PRAHA	620	25
Hotel DUO 4*	PVA EXPO PRAHA	330	13
Václavské náměstí (Wenceslas Square)	PVA EXPO PRAHA	600	24



ACCOMMODATION

FFF organiser offers a wide choice of partner hotel accommodation throughout the best locations in Prague for best available prices.

Easy [online reservation](#) system is available. For more details please contact Mrs. Pavla Sebestova, Forum Coordination Manager, at booking@future-forces-forum.org or by phone at +420 602 373 800.

Vienna House Diplomat Prague ****

Single Room / Double Room **120 EUR / 130 EUR** per room per night
Price includes **Breakfast, Wi-Fi, access to fitness, VAT**
Distance from PVA EXPO PRAHA **14 km** (22 min by car)

- * **This hotel hosts the FFF VIPs and official delegates.**
- * **Bus transfer to/from PVA EXPO PRAHA** (limited availability)



International ****

Single Room / Double Room **109 EUR / 119 EUR** per room per night
Price includes **Breakfast, Wi-Fi, access to fitness, VAT**
Distance from PVA EXPO PRAHA **14,5 km** (25 min by car)

- * **This hotel hosts the FFF VIPs and official delegates.**
- * **Bus transfer to/from PVA EXPO PRAHA** (limited availability)



Ibis Old Town ***

Single Room / Double Room **111 EUR / 123 EUR** per room per night
Price includes **Breakfast, Wi-Fi, VAT**
Distance from PVA EXPO PRAHA **12 km** (18 min by car)



Hotel DUO ****

Single Room / Double Room **99 EUR / 99 EUR** per room per night
Price includes **Breakfast, Wi-Fi, VAT, access to swimming pool, sauna and fitness**
Distance from PVA EXPO PRAHA **4 km** (8 min by car)



987 Design Prague Hotel ****

Single Room / Double Room **140 EUR / 140 EUR** per room per night
Price includes **Breakfast, Wi-Fi, VAT**
Distance from PVA EXPO PRAHA **10 Km** (24 min by car)





ACCOMMODATION

Holiday Inn ****

Single Room / Double Room **139 EUR / 149 EUR** per room per night
Price includes **Breakfast, Wi-Fi, VAT**
Distance from PVA EXPO PRAHA **15 km** (30 min by car)



Occidental Praha ****

Single Room / Double Room **105 EUR / 115 EUR** per room per night
Price includes **Breakfast, Wi-Fi, access to fitness, VAT**
Distance from PVA EXPO PRAHA **19 km** (30 min by car)



Occidental Praha FIVE ****

Single Room / Double Room **115 EUR / 137 EUR** per room per night
Price includes **Breakfast, Wi-Fi, access to sauna and fitness, VAT**
Distance from PVA EXPO PRAHA **17 Km** (30 min by car)



Pyramida ***

Single Room / Double Room **101 EUR / 113 EUR** per room per night
Price includes **Breakfast, Wi-Fi, access to swimming pool and fitness, VAT**
Distance from PVA EXPO PRAHA **14 Km** (23 min by car)





GENERAL INSTRUCTIONS FOR EXHIBITORS

A.	Timetable	6
	A.1. Assembly period	
	A.2. Dismantling period	
	A.3. Opening hours for exhibitors	
	A.4. Opening hours for visitors	
B.	Access, Badges and Vehicles	6
	B.1. Exhibitor registration desk	
	B.2. Exhibitor badges	
	B.3. Assembly and dismantling badges	
	B.4. Customer and business partners' registration	
	B.5. Visitors badges	
	B.6. Entrance of vehicles to PVA EXPO	
	B.6.1. Assembly period	
	B.6.2. Dismantling period	
	B.6.3. Exhibition period	
	B.6.4. Overnight parking during the exhibition	
C.	Realisation of expositions	6
	C.1. Takeover of the exhibit space	
	C.2. Waste removal	
	C.3. Forwarding service, customs clearance	
	C.4. Security	
	C.5. Electricity, water/drainage connection	
	C.6. Hanging points/suspension	
D.	Services for Exhibitors	7
	D.1. Stand cleaning	
	D.2. Staff (hostesses, translators, security)	
	D.3. Custom declaration of trucks	
	D.4. Import licence	
	D.5. Advertising within the fairground	
	D.6. Accommodation	
	D.7. Matchmaking	
	D.8. First aid service	
	D.9. Catering	
E.	Useful Information A -Z	7
	E.1. Admission to expert events	
	E.2. Copy Centre	
	E.3. ATM/Cash machine	
	E.4. Cloak rooms	
	E.5. E-invitation	
	E.6. Exhibition Management	
	E.7. Exhibitors' reception – Hangar party	
	E.8. Information Desk	
	E.9. Insurance	
	E.10. Internet connection	
	E.11. Meeting rooms	
	E.12. Onsite payment	
	E.13. Press Centre	
	E.14. Smoking and manipulation with open fire	
	E.15. Visa requirements	



GENERAL INSTRUCTIONS FOR EXHIBITORS

Please pay attention to the following instructions to ensure your smooth participation in the Future Forces Exhibition 2018.

A. TIMETABLE

A.1. ASSEMBLY PERIOD

Sunday 14 October – Tuesday 16 October 08.00 - 20.00

On the last day of assembly period, Tuesday 16 October, all construction material and transport packaging must be removed from the exhibition hall corridors until 18.00 in order to ensure the general cleaning and carpet laying.

Advance assembly is possible on Saturday 13 October and is charged according to size of the exhibit area.

A.2. DISMANTLING PERIOD

Friday 19 October 16.00 - 24.00

Saturday 20 October 08.00 - 24.00

All exhibitors have to stick to the given time schedule due to the security reasons.

A.3. OPENING HOURS FOR EXHIBITORS

Wednesday 17 October 08.00 - 18.00

Thursday 18 October 08.00 - 18.00

Friday 19 October 08.00 - 24.00

A.4. OPENING HOURS FOR VISITORS

Wednesday 17 October 09.30 - 17.00

Thursday 18 October 09.00 - 17.00

Friday 19 October 09.00 - 16.00

Presence of the exhibitor's representative at the exhibit stand during the opening hours is mandatory.

B. ACCESS, BADGES and VEHICLES

B.1. EXHIBITOR REGISTRATION DESK

Exhibitor Registration Desk is situated in the Entrance Hall 1 (VH1) and is open during the entire assembly, exhibition and dismantling period.

B.2. EXHIBITOR BADGES

Exhibitor badges will be issued based on the online registration and submission of the "Badge Order Confirmation" onsite at the Exhibitor Registration Desk.

Number of issued exhibitor badges: Exhibit space up to 15 m² gets 3 badges free of charge. For each additional 5 m² of exhibit space the exhibitor gets one more badge free of charge. Extra badges will be charged for 15 EUR/badge on-site. Payment is possible during the pick-up at the Exhibitor Registration Desk. Each exhibitor can receive up to 20 badges free of charge.

B.3. ASSEMBLY and DISMANTLING BADGES

Required number of the badges for exhibitors and contracting companies will be issued free of charge at the Exhibitor Registration Desk during the assembly and dismantling period.

B.4. CUSTOMERS AND BUSINESS PARTNERS REGISTRATION

Each exhibitor and co-exhibitor will receive e-invitation to the exhibition for business partners. On-line registration is available on the FFF website in section "REGISTRATION".

B.5. VISITOR BADGES

Visitor badges will be issued at the Visitor Registration Desk in the Entrance Hall 1.

B.6. ENTRANCE OF VEHICLES TO PVA EXPO

B.6.1. ASSEMBLY PERIOD

Sunday 14 October and Monday 15 October 08.00 - 20.00

Free of charge with the Assembly/Dismantling Parking Card only. The card will be issued at the Exhibitor Registration Desk.

Tuesday 16 October 08.00 - 20.00

Entry is possible only on a refundable **deposit of 1000 CZK** for the limited period of 3 hours. Assembly/Dismantling Parking Card is not valid for this day. After unloading the vehicle to the exhibition hall, please park the vehicle at the parking lot.

B.6.2. DISMANTLING PERIOD

Friday 19 October 16.00 - 24.00

Saturday 20 October 08.00 - 24.00

Free of charge with the Assembly/Dismantling Parking Card only. The card will be issued at the Exhibitor Registration Desk.

B.6.3. EXHIBITION PERIOD

Parking by Exhibition Halls

Wednesday 17 October & Thursday 18 October 08.00 - 18.00

Friday 19 October 08.00 - 17.00

3-day Parking Card 1000 CZK incl. VAT

1-day Parking Card 400 CZK incl. VAT

Parking Cards will be issued at the Exhibitor Registration Desk.

Parking at the Visitor/Exhibitor parking lot

Wednesday 17 October 08.00 - 18.00

Thursday 18 October 08.00 - 18.00

Friday 19 October 08.00 - 17.00

Single day parking fee is 180 CZK incl. VAT.

Multiple days parking fee is 150 CZK/day incl. VAT.

B.6.4. Overnight and 24-hours parking during the exhibition:

Possible only on designated parking places. Overnight and 24-hours Parking Cards will be issued at the Exhibitor Registration Desk.

Vehicle up to 3,5t or car trailer 500 CZK/night

Vehicle over 3,5t or truck trailer 750 CZK/night

24-hour parking for trucks or trailers 1000 CZK/24 h

C. REALISATION OF EXPOSITIONS

For order of the complete realization of exposition please contact the Exhibition Manager, Mrs. Marcela Marková at marcela@future-forces-forum.org.

In case of hiring other company for your stand construction, the standard fire instructions (use of non-flammable materials) and other technical requirements (mainly compliance with electrical standards) must be followed. For own stand construction it is necessary to submit the form "CONFIRMATION OF OWN STAND CONSTRUCTION" in the section "ORDER FORMS".

C.1. TAKEOVER OF THE EXHIBIT SPACE

Before the start of construction of the exposition, all exhibitors /stand constructors are obliged to take over the exhibit space by completing the appropriate form with the Exhibition Hall Staff (Hall Master).

After dismantling of the exposition, the same procedure is required to check the actual exhibit space condition. Please note that the Exhibition Hall Staff will accept absolutely clean area only. The Hall Staff will be present in the Exhibition Halls during the entire assembly, exhibition and dismantling period.

The assembly team has to stick paper tape beneath the double-side tape when sticking carpet on the floor in the Exhibition Hall for proper removal during dismantling, otherwise costs of removal are charged directly to the exhibitor. The paper tapes are sold at the Exhibitor Registration Desk.

C.2. WASTE REMOVAL

All construction companies must remove any waste and extensive packaging materials by themselves. Waste containers will be placed nearby the exhibition halls during the assembly period only. During the dismantling period, it is strictly forbidden to place any construction material in the waste bins (with the exception of minor waste). It is possible to dispose the construction material via the Organiser (charged service).

C.3. FORWARDING SERVICE, CUSTOMS CLEARANCE

It is possible to order the services from official forwarding agent CENTRUMSPED. Detailed information and services please find in the section "GENERAL CARGO SHIPPING INSTRUCTIONS".

CENTRUMSPED ensures the following services for exhibitors: Temporary storage, custom clearance and documentation, handling of exhibitors' cargo, handling of empties, professional labour assistance, and special logistics solutions.

In case of transporting the exhibits within customs control, it is necessary to consult the import procedure and the possible re-export with CENTRUMSPED. CENTRUMSPED team will be present during the assembly and dismantling period.

C.4. SECURITY

Organizer ensures the general overnight security within the exhibition halls. Timing is as follows:

During the night on 16 October	20.00 - 08.00
During the night on 17 and 18 October	18.00 - 08.00

Security staff at the Entrance and Exit gate might require a list of imported exhibits and check of the cargo. Exhibitors might be a subject to a random check while leaving the PVA EXPO PRAHA.

Security of particular exposition/exhibits is not included in the general service. For the stand security service order please contact the Organiser.

C.5. ELECTRICITY, WATER/DRAINAGE

Technical mains to your exposition are provided exclusively by the PVA EXPO PRAHA staff.

Please refer to the "TECHNICAL MAINS & SERVICES" in section "ORDER FORMS".

C.6. HANGING POINTS/SUSPENSION

Please send your request with all technical details to Organizer not later than on 14 September 2018. The quotation is made by PVA EXPO PRAHA individually.

D. SERVICES FOR EXHIBITORS

D.1. STAND CLEANING

Cleaning can be ordered via the "TECHNICAL MAINS & SERVICES" in section "ORDER FORMS".

D.2. STAFF

Hostesses, translator and the security service can be ordered by contacting the Organiser.

D.3. CUSTOM DECLARATION OF TRUCKS

Please refer to the "GENERAL CARGO SHIPPING INSTRUCTIONS".

D.4. IMPORT LICENCE

Any military and security material, weapons and ammunition must be imported legally. The **import licence** for the exhibits can be issued by FFF import licence partner, company Omnipol.

Contact: Mrs. Vlasta Dvořáková
Email: dvv@omnipol.cz
Tel.: +420 224 012 252

D.5. ADVERTISING WITHIN PVA EXPO PRAHA

Please refer to the "OTHER PROMOTION OPTIONS" in section "ORDER FORMS".

D.6. ACCOMMODATION

The Organiser offers accommodation in downtown Prague as well as nearby PVA EXPO PRAHA for beneficial prices. For detailed information please refer to the section "ACCOMMODATION".

D.7. MATCHMAKING

Matchmaking programme is a part of the FFF networking. It is a tool for arranging formal or informal meetings of registered participants, exhibitors, partners and official guests. More information is available online - <http://www.future-forces-forum.com/matchmaking>.

D.8. FIRST AID SERVICE

Emergency service will be located at the Exhibitor Registration Desk during the entire exhibition.

D.9. CATERING

For order of catering service please contact the Exhibition Manager, Mrs. Marcela Marková at marcela@future-forces-forum.org.

E. USEFUL INFORMATION A - Z

E.1. ADMISSION TO EXPERT EVENTS

All exhibitors' representatives will get free admission to expert events. Organiser provides 50% discount for exhibitors' business partners. Invitation with a special discount validation code will be sent together with e-invitation.

E.2. COPY CENTRE

Copy centre is located in the Entrance Hall 1.

E.3. ATM/CASH MACHINE

Cash machine is located in the Entrance Hall 1.

E.4. CLOAK ROOM

Cloakroom is available at the Entrance Hall and at the VIP Entrance Hall during the exhibition opening times.

E.5. E-INVITATION

All exhibitors will receive a PDF invitation to FFF for their business partners.

E.5. EXHIBITION MANAGEMENT

Exhibition Management Office is located at the Exhibitor Registration Desk.

E.6. EXHIBITORS' RECEPTION – HANGAR PARTY

The exhibitors' official evening reception will take place on Wednesday 17 October at 20.00 - 24.00 in the hangar H51, 24 Air Base Kbelly. Each exhibitor will get one free admission to the party. Additional passes can be ordered in section "OTHER PROMOTION OPTIONS" of the "ORDER FORMS".

Due to security measures, names and position of company representatives must be submitted no later than Friday 14 September to marcela@future-forces-forum.org.

Printed invitation with the participant's name will be ready for pick up at the Exhibitor Registration Desk at PVA EXPO PRAHA during assembly period and on 17 October at 08.00 - 18.00. Without a printed invitation, the entry will not be allowed.

E.7. INFORMATION DESK

Information Desk is open during the exhibition at the Entrance Hall. The Information Desk will provide information regarding live demonstrations programme as well as the expert events programme.

E.8. INSURANCE

We recommend insuring your exhibits. In case of your interest in arranging the insurance of the exposition/exhibits, please contact the Organiser with your request till 14 September 2018.

E.9. INTERNET CONNECTION

Wi-Fi or wired connection can be ordered via "ORDER FORMS" in section "TECHNICAL MAINS & SERVICES".

In order to avoid any inconvenience, we ask exhibitors to inform the Organiser about intend to use your own Wi-Fi technologies within the Exhibition Halls. Using Wi-Fi networks which are not provided by PVA EXPO PRAHA can cause problems with the Wi-Fi signal at PVA EXPO PRAHA.

E.10. MEETING ROOMS

The organizer provides rooms for your own presentations, meetings or receptions. Any type of catering service may be provided in the meeting rooms. Booking request must be made via the "ORDER FORMS" in section "OTHER PROMOTION OPTIONS". A detailed quotation will be tailored to the exhibitor's requirements.

E.11. ONSITE PAYMENT

Onsite payment of fees will be possible only by cash or VISA, MAESTRO and MASTERCARD. Please note that we do not accept American Express cards.

E.12. PRESS CENTRE

Press Centre is located in the Entry Hall. Exhibitors are welcome to share press releases and PR materials with accredited journalists and media representatives.

E.13. SMOKING AND MANIPULATION WITH OPEN FIRE

Smoking and manipulation with open fire is strictly forbidden in exhibition halls.

E.14. VISA

Entry visa may be required to enter the Czech Republic. For information regarding the visa requirements please see the General Visa Information of the Czech Ministry of Foreign Affairs. Please refer to the corresponding Czech Republic embassy for further assistance. The Organiser will issue the visa confirmation/invitation letter to exhibitors and partners.



INSTRUCTIONS FOR EXHIBITORS OF MILITARY OR SECURITY MATERIAL, WEAPONS AND AMMUNITION AT THE FUTURE FORCES EXHIBITION 2018

These instructions are complement to General instructions for exhibitors.

At the **FUTURE FORCES EXHIBITION 2018, and at conferences and presentations held during 17-19 October 2018 at PVA EXPO PRAHA /hereinafter also FF18/**, exhibiting of weapons, ammunition, military and security material in compliance with the legislation of Czech Republic is allowed.

1. All Exhibits of Weapons and Ammunition are divided by the Act 119/2002 Sb. /hereinafter Act/ into the following categories, hereinafter Cat. (abbreviated wording of legislation is included). The complete wording of the Act and Regulations for FF18 are available at the Armourer for foreign exhibitors, police and security reasons.

1.1. Weapons of Cat. A, B or C, registered according to the Arms and ammunition Act No. 119/2002 Sb., based on the application of the Exhibitor from Czech Republic, who is their rightful owner. Also, stand-alone main parts of such weapons are subject to registration.

Weapons of Cat. A, B or C, registered according to the Arms and ammunition Act No. 119/2002 Sb., based on the application of the Exhibitor from Czech Republic, who is their rightful owner. Also, stand-alone main parts of such weapons are subject to registration. Exhibition Organizers are opposed to support of illegal presentation, therefore will allow only presentation of weapons, ammunition and its accessories in this Category, which are allowed by the legislation of Czech Republic or the Exhibitor's country. Foreign Exhibitors will also present document (certificate with sworn translation or legislation in English or Czech language) from the legally empowered authority of the given state. The Exempted are exhibits of foreign exhibitors from E.U. member states and Countries, which ratified C.I.P. principles. The Exhibitors are obliged to have written documents, on safety of such exhibit in Czech or English, language on them. The Exhibits will be approved by the Police and the Exhibition Armourer, in case of need after consultation with the Czech Proof House for Arms and Ammunition; (www.cuzzs.cz).

1.1.1. Weapons Cat. A "Prohibited" – military, automatic, manufactured not from metals, deceitful, with integrated sound suppressors and Night-Vision sights, shooting booby-trap devices, ammunition with armour-piercing, explosive or incendiary bullet. Prohibited weapons are also accessories of weapons – sound suppressors, aiming devices for weapons designed as Night-Vision.

1.1.2. Weapons Cat. B "Subject to permit" – short repeater or self-loading, short single-shot or multi-shot weapons and centre-fire or rim fire ammunition of overall length up to 280 mm, long self-loading weapons with capacity exceeding 3 rounds, repeater and self-loading smooth-bore with barrel shorter than 600 mm, self-loading weapons with appearance of automatic weapons and signal weapons with calibre above 16 mm.

1.1.3. Weapons Cat. C "Subject to declaration" – weapons single- and multi-shot for rim fire ammunition with overall length of 280 mm and greater, gas weapons with energy $E_{0min}=16$ J except Paintball weapons; more than two-shot percussion and single- and multi-shot, repeater or self-loading long weapons, not mentioned in Cat. B;

1.2. Weapons Cat. D "Other not mentioned in Cat. A, B, C" – historical weapons manufactured up to 1890; Flobert type with $E_{0max}=7.5$ J; gas operated with air cartridge and with $E_{0max}=16$ J; expansion; mechanical with draw force exceeding 150 N; deactivated weapons and their sections (see also section 1.2.); non-active ammunition, mock-ups of weapons, ammunition and ordnance.

Weapons of Cat. D, in compliance with section 15 of the Act No. 119/2002 Sb., based on the application of the Exhibitor from the Czech Republic, which is their rightful owner. Deactivated weapons from countries which accepted C.I.P. are respected according to national standards with appropriate documentation (certificate) and permit issue is not required;

1.3. Weapons and ammunition which are acquired and owned in the stock of manufacturers, dealers from the Czech Republic according to law, will be listed according to valid categorization; This division has to be maintained for weapons in the documentation for registration and record-keeping on the Exhibition. Exhibitors both from Czech Republic and abroad register weapons and ammunition on the attached Form "List of exhibits".

2. Military material according to the Act No. 38/1994 Sb., on foreign trade with military material (hereinafter VOJMAT) and ordinance **No. 48/2015** (hereinafter VOJMAT list and specimens of forms).

Import of exhibits of foreign exhibitors, according to Act no. 38/1994 Sb. has to be secured via valid license of Czech-based company or a sole-proprietor (for EU-based companies), which possess valid permission for foreign trade on military materials.

The Military material for exhibitors will be registered on FF18 in a separate form No. 4, in which in column 1 of the table a reference will be made to section 5 of the Act 38/94 Sb.; in the column No. 2 the SVMe Number (according to ordinance 48/2015 Sb.), in the column 3 the name of the material and other identifying data of the product. If the application subject is **substantial military material** (Sec. 20 of the Act No. 38/1994 Sb.), identification (serial) numbers of the military material have to be specified in the application (newly manufactured goods, with no identification number assigned, are excluded).

3. Security Material /BeM/ is regulated by the Act No. 229/2013 Sb. and by the ordinance 295/2014 Sb. is subdivide it into groups.

Group 1: Flamethrowers or producers of smoke or gas which cause immobilization of person, its injury or dead, if they are operational.

Group 2: Mine primers, if they are operational

Group 3: Systems and subsystems for fire control and missile guidance, if they are operational

Group 4: Armoured and military engineering vehicles on tank chassis, if they are operational, except those used by integrated rescue system

Group 5:

a) Tanks, AFVs, APCs, combat vehicles with heavy weaponry, self-propelled artillery systems, including guns, mortars, howitzers, rocket launchers and systems combining their characteristics, with weapon irretrievably deactivated according to other legislation in manner to prevent its repeated use for military purposes, or vehicles equipped with weapons carriers or equipment for mine-laying or ammunition firing

b) Bridge tanks and other armoured vehicles and carriers, especially with special attachments or derived from vehicles under letter a)

Group 6:

a) Military aircrafts, helicopters and other aircrafts and helicopters with special construction characteristics related with military usage made after 1 January 1946, if they are operational

b) Combat unmanned aerial vehicles lighter or heavier than air, with or without engines, autonomous or remote-controlled and other unmanned vehicles with special construction characteristics related with military usage, if they are operational

Group 7: Electronic countermeasure devices and devices for protection against ECM (i.e. equipment for transmit of error or false signals to radars or communication devices, or to different disruption of transmission, operation or effectiveness of enemy electronic receivers), including jamming devices, specifically designed for the use by security services, if they are operational

Group 8:

a) Military simulators for attack, combat flights, radar reconnaissance, gen-

erators of radar signatures, equipment for artillery training, ASW simulators, flight simulators (including centrifugal simulators for flyers and cosmonauts), radar simulators, simulators for navigational flying, navigational simulators, simulators of guided missile launching, equipment for target visualization, for UAVs and its simulators, trainers of armament, if they are operational

b) Systems for production of imaging and interactive space for simulators, if they are especially designed for military use

Group 9: Military installations, technology, materials and its specifically designed parts,

Group 10:

a) Portable laser equipment, which contains laser falling into class of danger 3R, 3B or 43 according to ČSN EN 60825-1 ED2, such laser equipment can be adapted to creation or amplification of coherent electromagnetic glow visible for human eye and which can be used to focus laser beam on specific target and disrupt its performance

b) passive monitoring systems

c) laser systems designed specifically for target destruction or performance disruption of target

d) systems for particle beams able to destroy target or disrupt its performance

e) high-output high-frequency systems able to destroy target or disrupt its performance

f) high-output high-frequency systems able to destroy target or disrupt its performance

Group 11: Photographic and electro-optical devices and equipment of unmanned vehicles under group 6, if they are operational

Security material on FF18 is registered on the Form No. 4 for domestic exhibitors, including the subdivision into above mentioned groups – BeM/Group number. Eventually use the “comment” column.

3.1 All weapons, ammunition, military and security material specified as “exhibit” for exhibition must be “deactivated”. Deactivation is the responsibility of the exhibitor; implementation is verified by the Exhibition Armourer. Exhibit deactivation represents temporary modification preventing, in case of attempt of use with appropriate ammunition, discharge, movement of mechanisms, systems, and radiated energy exceeding hygienic standards, which could endanger life or health of the Exhibition visitors. It is carried out by removal of groups, parts, shortening of the firing pin by its protrusion, while the parts are not present in the allocated exhibition premises. Removal, locking of the trigger mechanism, bolt or barrel with security lock, and prevention of weapon loading is also considered “deactivation”. Ammunition and ordnance deactivation is carried out only by demilitarization! Where the specified procedure is inappropriate, the exhibitor will propose suitable procedure, while presenting necessary documents no later than on **15 Oct 2018**. The suitability is approved in writing for the “Exhibitor’s Technical project” by the FF18 Exhibition Armourer (tomas.mazuch@perunarms.cz). Acceptance of exhibits will be confirmed on 16 Oct from 13.00 to 18.00 by armourer and state governance. In case of imperfections the exhibitor shall eliminate them during this time, otherwise will not be permitted to exhibit them.

3.1.1 Demilitarized weapons and sections (Cat. A/Z, or B/Z, C/Z or D) – are permanently or irreversibly modified in order to make mechanisms facilitating shooting inseparable and their relative movement is not possible. In revolver systems the walls of individual chambers are machined-out (full wording of procedure for demilitarization and destruction of a weapon, ammunition and section manufacture, is contained in regulation 219/2017). Unless stated by legislation otherwise, demilitarization according to regulation 219/2017 Sb. is deemed valid for exhibitors from Czech Republic. Foreign exhibitors shall obey EU legislation stated in regulation of Commission 2015/2403 (valid from 8 Apr 2016), or according to national legislation of country of exhibitor’s origin, which will comply with Commission act 2015/2403. Such method should be confirmed in writing to exhibition’s armourer.

For the weapon section (Cat. D/R) movement of main parts and weapons mechanism and possible disassembly is acceptable. The use of the main parts as spare parts for functional weapons must be prevented. Barrel, frame, breech milled-out, firing pin shortened. The shot may not, in attempted discharge, leave the barrel. Magazine is milled out on the side and back wall.

Marking (by authorized person) of the demilitarized weapon with “control demilitarization marking” has to be carried out by stamping on at least one main part in a visible and permanent manner and the Exhibitor has a valid certificate of demilitarization-section. Demilitarization of weapons are not, from the security standpoint, registered weapons, meeting the requirements of the article 63 the Act No. 119/2002 Sb., on firearms and ammunition, as amended. However, they are under evidence of Armourer with certificate from exhibitor, that they have been demilitarized according to effective legislation and that they are safe.

3.2. The group of non-active weapons and ammunition (Cat. D/N) consists of:

3.2.1. Dummy ammunition (Cat. D/Sk), which is specifically manufactured and marked for training in manipulation and loading of weapons and its elements cannot be used for standard ammunition; contains no combustible or explosive substances. Due to non-standardized marking of “dummy ammunition” by manufacturer, the Exhibition acceptance inspection (eventually beforehand, agreed between the Exhibitor and the FF18 Armourer) is carried out by the Armourer, which decides on eventual exclusion of an exhibit from the Exhibition grounds in case the exhibit is not accompanied by appropriate certification of origin and condition;

3.2.2. Demilitarized ammunition (Cat. D/R), on which irreversible modifications have been carried out, preventing further use for shooting and which is marked according to Regulation No. 219/2017 Sb. Ammunition and ordnance does not contain incendiary or explosive compounds; primer has to be removed from exhibits or it shall be drilled in diameter of 1,5 mm;

3.2.3. Mock-Ups (Cat. D/A) of weapons and ammunition are products resembling, in appearance and dimensions, material used as master. The material used for manufacture and especially its internal disposition absolutely eliminates use, usual for the master. Mock-ups do not contain parts from the master manufacture. They are usually manufactured from wood, plastic, rubber or other substituting material;

3.2.4. Models (Cat. D/M) contain parts from the master manufacture, otherwise same as mock-up.

Mock-ups and models are not subject of registration according to Act no. 119/2002 Sb. and restricted mode of foreign trade. However, they are listed with the appropriate category, by which means the Exhibitor declares the exhibit’s condition.

3.2.5. For the purposes of import and export for public exhibition a license, according to legislation, **is not required**, if the exhibit is originally military weapon or military ammunition – see Section 4 of the Act No. 119/2002 Sb., **which are declared as already modified – demilitarized** and appropriate certification is available. However the Organizer recommends the Exhibitors to verify with their national Authority the listed conditions for export and later import of exhibits. The Armourer and his team will assess compliance of demilitarization method and will document the fact in writing for each of the weapons or ammunition in the Form No. 1 or 4 by the Exhibitor and centrally in the Exhibition Acceptance Certificate. In case of non-compliance of the demilitarization method with the Regulation 219/2017 or with national standards of C.I.P., handling of such material is possible only within restricted mode of foreign trade.

3.2.6. Exhibitors’ List of weapons, ammunition, ordnance, military and security material on the exhibition grounds of the Czech Ministry of Defence will be handed over to the Exhibition Armourer together with written declaration on execution of inspection of safety of the exhibits till 15 Oct 2018 at 08.00 at the latest. This list will contain also written statement of security measures of these exhibits during inspection day (16 Oct 2018). Up-date of this list will be eventually delivered in writing on the inspection day at 13.00 at the latest.

4. Weapons and Ammunition for practical demonstration:

Practical demonstration of weapons, their accessories, ammunition and exhibits, which cannot be carried out on the Exhibit grounds – (permitted extent only by the technical project, threat by shooting, noise, radi-

ation etc.), is organized by the Exhibitor based on contract according to the laws of Czech Republic. This service, charged, can be arranged for foreign exhibitors by the FF18 exhibition Armourer, based on the Exhibitor's request, sent to the Exhibition Organizer **no later than on 11 Oct 2018**. The exhibits are then taken over according to the Form No. 5 or 1 by the Armourer, or Deputy, which provides for their storage outside the exhibition grounds, usually in the demonstration location. For the purposes of demonstration the exhibitor will state known (required) data:

- Date, time of demonstration, expected number of participants and required extent of demonstration, together with contact info and statement of need for commercial from Organizer of the exhibition,
- Exhibit parameters and extent of security measures for demonstration, endangered space, need for security measures and who will be responsible for presentation and his qualification
- Whether requiring security of the demonstration premises, furnishing, transportation of participants to the approved shooting range, etc.

5. Gift Weapons and Ammunition are subject of written consent of the Exhibition Organizer. The Exhibitor can give a visitor gift in the form of only such weapons and ammunition (or their parts), which according to Czech legislation are not subject of registration, record-keeping and state supervision.

Document for removal of such exhibits from the Exhibition Grounds is "Permit for removal of weapons, ammunition", which is issued upon request (1 day in advance, in exceptional cases min 4 hours prior to required time of removal) by the FF18 Exhibition Armourer.

REMOVAL OF EXHIBITS ON THE FINAL EXHIBITION DAY PRIOR THE END OF THE EXHIBITION (19 OCT 2018 at 16.00) REQUESTS EXHIBITOR NO LATER THAN ON 18 OCT 2018 TILL 12.00 AT THE ARMOURER.

6. GENERAL PROVISIONS:

6.1. The Armourer is responsible to the Exhibition Organizer for compliance with condition of safe-keeping of weapons, ammunition, ordnance, security and military material in the Exhibition Grounds according to the laws and is authorized to issue binding instructions to the security personnel and exhibitors. The Armourer maintains records of exhibits-weapons and ammunition, security and military material, partially performs duties especially with regard to Sections 40, 61 of the Act No. 119/2002 Sb., amended by the "Exhibition FF18 Security Project". Security project and Exhibitor instructions are part of Internal regulation according to Section 39, para 1d of Act No. 119/2002 Sb. In the event of emergency situation management the Armourer directs activities until police intervention. Overall supervision over exhibits in the Military Area, in compliance with Czech Army legislation, is maintained by the "Security Manager of MOD for FF18" and, under his command, Military Police. Directive of the MOD for FF18 will be handed over to armourer no later than on 11 Sep 2018 to the Armourer. The Exhibition Armourer is authorized to perform inspection and issue binding instructions for compliance with Czech legislation in the FF18 Military Area, amended in Exhibition conditions in the FF18 Security Project. In the event of emergency situation management the Armourer directs activities until the intervention of Integrated Rescue System. During his absence and in allocated tasks the Armourer is represented by the Deputy Armourer – Vladimír Maršík.

6.2. The exhibitor, holder of weapon license and "responsible person" appointed by him – holder of weapons license of the appropriate groups, are responsible for preparation of weapons and ammunition for public exhibition, for documentation of rightful ownership and actual technical condition of the Exhibit. Such person has to be stated on form No. 4.

Any changes in records of Exhibits – weapons and ammunition, military and security material have to be announced by the Exhibitor to the Armourer in writing without unnecessary delay. The responsible person for a foreign exhibitor is the "importer". Based on instruction of the FF18 Organizer the duties of the "responsible person" are temporarily carried out by the Authorities and the Exhibition Armourer. The Exhibitor is obliged to install the Weapons and ammunition Exhibits in the acceptance day (16 Oct 2018), at 17.00 at the latest, in order to allow the Armourer and the public governance authorities to inspect the Exhibition and hand it over to the security service, which documents the condition of the accepted exhibition by photographs, for guarding at 18:00. Threats, risks and measures are elaborated in the "Security Project of FF18" and fulfilment of Exhibitor's obligation is verified by the public administration authorities – Municipal HQ of Czech Police Prague - MěR

PČR Praha (at exhibition of foreign exhibitors also the Customs service) and the Armourer – during acceptance (on the 16 Oct 2018 from 13.00 to 18.00), further as needed.

6.3. The Exhibitor will state for each exhibit of weapon required information on the appropriate form No. 4 "List of Exhibits – Weapons and Ammunition". For ammunition it is sufficient to state (in the same form) the manufacturer, standard commercial designation and amount. **Send the Forms by E-mail to: tomas.mazuch@perunarms.cz and in copy to armourer48@gmail.com till 11 Sep 2018 at the latest. Later, send the filled-out and approved printed originals of the forms to the Organizer with note "for the Exhibition Armourer" on 14 Sep 2018 at the latest.** Specification is possible by personal presentation of a new form No. 4 (or No. 2 for imported weapons) at the Armourer's office, on the Exhibition acceptance day – until 09:00!

6.4. All Exhibits- Weapons and Ammunition (registered for the Exhibition and specified until the Exhibition acceptance) will be placed in the Exhibition in:

- a) Locked glass boxes
- b) Lockable exhibition boxes, accessible only by the Exhibitor and sealed for the time of being handled to Security agency;
- c) On installed stands, walls, to which they are fastened (lock, cable);
- d) Otherwise – according to the Exhibitors proposal, in compliance with prevention against theft, abuse, and approved by the Exhibition Armourer and Acceptance Commission.

In case of situation, when Exhibitor creates any threat to life or health of visitors, Exhibitor can be ordered to leave exhibition immediately, without entitlement to return of payed fees.

Removal of exhibits – weapons and ammunition outside of the designated Exhibition Grounds has to be agreed with the Exhibition Organizer (eventually with the Armourer). In the event of removal of exhibits from the Hall the Armourer issues upon the request of the Exhibitor a written certificate, on compliance with the Act No. 119/2002 Sb. Such Exhibitor's request, for the last day of exhibition has to be delivered to the Armourer **on 18 Oct 2018 until 12.00 at the latest.**

6.5. All participants of the FF18 Exhibition are obliged to subject to detection check, according to needs, performed on the exhibition grounds. It is prohibited to carry in or out any weapons and ammunition to – from secured space, excluding replenishment of supplies and potential presentation.

6.6. In the event of the breach of instructions and the Law the Exhibition Organizer or the public administration (Czech Police, MPO/LS) may cancel the permit for exhibition of weapons and ammunition for the particular Exhibitor.

6.7. In the event of the Exhibitor of weapons and ammunition will not be present on his stand at least 15 minutes prior to opening hours for public, the Organizer provides individual guarding, which will be invoiced to the Exhibitor at the rate of CZK 900 (36 EUR) for every started hour of guarding. The Exhibitor is obliged to take all measures to secure his exhibition. The Exhibitor is obliged to have his exhibition over to the Security (45 minutes after Exhibition closing at the latest) and to take it over from the Security (at 08.45 every day). During the time between take over from the Security until the hand over to the Security the Exhibitor has to control the exhibits at all times. If the Exhibitor is lending the exhibits – weapons, ammunition, military and security material to a visitor, he has to take such measures to prevent injury through untrained manipulation and theft. The Exhibitor demonstrates the Acceptance Commission readiness of the Exhibition and presents required documents of weapons' and ammunition registration. In case of need, during the inspection by the public administration authorities, a foreign exhibitor calls the Armourer GSM: +420 608 432 224.

6.8. The Exhibitor may request above-standard security of the rented space by the FF18 Armourer as a paid service. Any form of securing the Exhibition has to be part of the "Exhibition Technical Project", subject to approval by the Armourer. Individual security of the stand during the opening hours of the Exhibition, by the Security Service without a firearm is possible. The Exhibitor will announce it in writing to the Armourer on Form No. 4 or 2. Exhibition Organizer in cooperation with the Armourer has to approve the use of exhibition spaces outside of opening hours for social or other activities of the Exhibitors.

6.9. Should the Exhibition administration issue instructions to evacuate the

Hall (see General conditions of participation and Exhibition Grounds Emergency Plan), the Exhibitors of weapons, ammunition, military and security material will leave a responsible person in the exhibition to guard the exhibits until they receive instructions from the Armourer or Security Agency for handover of the Exhibitions for guarding.

6.10. Disassembly of Exhibits – weapons and ammunition on 19 Oct 2018 starts by storage and securing the weapons, ammunition, security and military material. The Exhibitors, whose Exhibits were taken over by the Security Agency (Military Police), are allowed to start inventory and storage of weapons into transport packaging at 15.00. To enable bringing the packaging for weapons, early arrival of one Exhibitor's vehicle is allowed - the type, license number and driver's name will be announced to the Armourer on the 18 Oct 2018 at 10.00 at the latest. The Access Permit for vehicles bringing in packaging for weapons and ammunition is issued by the Exhibition Organizer.

From the time all Exhibitors of weapons and ammunition have secured those Exhibits, access for vehicles of other Exhibitors will be allowed for dismantling, perimeter security will be terminated at the same time. The Exhibitor is not allowed to terminate or interrupt the Exhibition dismantling if weapons, ammunition and valuable exhibits and possessions are still present. Removal of weapons and ammunition from the Exhibition into the transport packaging will be reported by the Exhibitor's responsible person immediately to the Armourer on his mobile phone: +420 608 432 224. From the termination of the Exhibition each Exhibitor is responsible for securing the weapons and ammunition within the Exhibition Grounds.

6.11. Entry with weapon (short firearm in concealed carry) into the secured area of the FF18 Exhibition between 18.00 on 16 Oct 2018 until 18.00 on 19 Oct 2018:

- Is allowed only to the "person responsible for exhibits – weapons and ammunition" – holder of Weapons Permit of appropriate group, to whom has been issued special permit by Armourer;
- Is not allowed to visitors and other Exhibitors.
- Weapons carry by Czech Polices and Military Police is not limited, providing they carry out their duties in accordance with FF18 Security Project.

Ordinary pocket knives are not removed from the exhibitors and visitors for purposes of security with the secured area. **Should the Exhibitor have an exceptionally valuable Exhibit in this group, it has to be registered in the "weapons" list and such item cannot be presented to visitors as a gift.** The security is organized by the Armourer as a complex – see instructions and "FF18 Security Project", approved by Czech Police.

6.12. Exhibits with specification of secret information (see Act No. 412/2005 Sb.) will not be presented on FF18 and no secured premises for secret negotiations are designed.

In case of questions and ambiguity please contact me prior to 3 Oct 2018 on GSM +420 608 432 224 eventually Armourer's Deputy phone/fax: +420 272 731 597, starting on 15 Oct 2018 at GSM: +420 602 742 346, tomas.mazuch@perunarms.cz during the Exhibition in the Armourer's office at PVA EXPO PRAHA. For more info about exhibition please see www.natoexhibition.org.

In Prague, on 14 Aug 2018

FF18 Exhibition Armourer

Tomáš Mazúch

LIST OF EXHIBITS

Weapon category according to the Instructions for Exhibitors of Military or Security Material, Weapons and Ammunition	Weapon category according to the Act §4-7 119/2002 Coll. BeM and SVMe	Type of weapon or material	Manufacturer	Model/Type	Calibre	Quantity	Serial number
1	2	3	4	5	6	7	8
Total							

We herewith confirm the completeness, accuracy and truthfulness of all information provided above and we are aware of possible legal consequences arising from the provision of false or otherwise distorted information. Upon the request of competent authorities of the Czech Republic in charge of import/export of material of military nature, we will provide additional information necessary for the issuance of the export/import license.

Information about any changes in the above list of exhibits will be provided to the organizer of the FUTURE FORCES Exhibition 2018 in written form. We are aware that any changes in the above mentioned list might be made only with a prior consent by competent authorities of the Czech Republic in charge of import/export of material of military nature and without their approval we will not import any other items that are not included in the list of exhibits to the Czech Republic.

Place

Date

2018

.....

Signature of authorized representative

LICENCES - INFORMATION FOR MILITARY AND SECURITY MATERIAL EXHIBITOR

EU Countries

The import license for the military material from the EU countries is no more needed. The exhibitors have to obtain transport permission of military material in their country of origin. We are ready to assist the exhibitors to receive either the End User Certificate or the International Import Certificate.

Non-EU Countries

The following **details** are **requested for the license proceedings**:

- 1) Declaration of military material exhibits
- 2) List of military material items to be displayed
- 3) Description of goods (brochure, leaflet, flyer etc.)
- 4) Filled and signed Agency Agreement + Confirmation

In case the exhibitor would like to display the military material that is subject to the licensing procedure, and do not have a business partner in the Czech Republic authorized for dealing with military material (according to the Czech law No. 38/1994Sb. about international business with military material), the organizer requires submitting the documents to Mrs. Vlasta Dvořáková, vlasta.dvorakova@omnipol.cz (FFF partner for licence procedures) and in CC to info@future-forces-forum.org.

Please send the above listed documents until 10 August 2018 at the latest.

Definition of military material (according to the Act No. 38/1994 on the foreign trade with military material) is as follows:

- a) **Products, its components and spare parts** which are, due to its characteristic technical and construction attributes, designed primarily for use in the Armed Forces or Security Forces, or are used by these forces to perform tasks of defence and national security.
- b) The **machinery, equipment and investment units, technologies, software, technical documentation and manuals** produced, adapted, designed or modified for military use, particularly for the development, manufacture, inspection and testing of other products, their components and spare parts referred to in para a).

Exhibits that are Subject to Special Norms

- 1) Devices for night vision
- 2) Armour-plated vehicles
- 3) Non-lethal weapons and ammunition
- 4) Gas grenades
- 5) Personal weapon systems
- 6) Other items that meets the criteria of weapon, ammunition, explosives, security material
- 7) Dummies
- 8) Inert weapons and ammunition
- 9) Scale models 1:1 or other scale including cross sections models
- 10) Weapons and ammunition designed for practical display

Purpose of Use

- 1) For display during the FF18 only. Shipment out of the Czech Republic will be ensured immediately after the end of FF18.
- 2) For display during FF18 and subsequent display in exhibitions, shows, events or similar contractual agreed purposes within the Czech Republic. Shipment out of the Czech Republic will be ensured right after the end of these events.

- 3) For entire consumption or devaluation during the FF18, subsequent contractual exhibition show or similar contractual agreed purpose within the Czech Republic.

Security Measures

All exhibits at the FF18 will be highly secured during the entire exhibition with the aim to ensure the highest level of convenience for exhibitors to guarantee and secure their property.

The entrance to the exhibition halls is strictly through the security area and security frames to ensure the safety of all exhibitors and visitors. The security measures and the Security Project are approved by the state authority. The Security Project (Information Security Management System - ISMS) creates complex solution of safety with the understanding of the international rules and standards ISO/IEC 27001 and other partial European norms, which are solved by particular segments of security. The FF18 organizer does not assume any secret information that can be part of the exhibits.

We kindly ask all the exhibitors who will have the following items among their exposition

Product Category According to the Application Form	Exhibit
117; 123	Military Space Systems; Radar Systems
201	Automatic Target Recognition
400; 500	Weapons; Ammunition
701; 702	Armed Robotic Vehicles; Combat Vehicles
804	Aircraft Armament and Munitions
1701	Night Vision Equipment
xxx	All other items that meet the criteria of military material

to send us a list of all these exhibits including the statement of the technical status:

- A) Temporarily Deactivated Weapons (dummy)**
- B) Permanently Deactivated Weapons (inert)**
- C) Scale Models (1:1 or other scale) including cutaways**
- D) Real Weapons (enabling immediate use as a weapon)**

It is also possible to request an individual security guard (at your own expense) for the whole exposition or a particular exhibit, setting technical devices (electronic security system) common in the Czech Republic, or installation of your own security system after the agreement with the FF18 armorer.

Scale models, inert weapons and ammunition that are not subject to license control are preferred in the exhibits. The method of practical display at the exhibition area must not cause harm to anyone. Armourer will decide in disputed situations.

The official **on-site handling and customs clearance agent**

is CENTRUMSPED s.r.o.

Phone +420 547 423 165

e-mail info@centrumsped.cz

Website www.centrumsped.cz

DECLARATION OF MILITARY MATERIAL

Exhibitors who will exhibit the military or security material and do not have a business partner in the Czech Republic should **submit these documents until 10 August 2018 at the latest.**

CONTACT DETAILS:

Company name:

Address:

Country:

Contact Person:

Phone:

E-mail:

Fax:

We hereby declare that all exhibits of military nature (see the attached Appendix 1 – List of Exhibits) will be handled fully in accordance with legal requirements of our company's home country. All items of military nature will be handled in a manner causing no conflict with the enforced legal requirements of the Czech Republic at any time of their presence at the Czech territory. Subsequent shipment of exhibited items out of the Czech Republic will be carried out no later than by the end of October 2018, otherwise agreed with the FF18 organizer.

We hereby declare that all the material of military nature we listed in the Appendix 1 (excluding material declared as category „D“) has been deactivated or made inert to such an extent that it is fully equivalent to all legal provisions of our company's home country. A professional representative of Future Forces Exhibition 2018 will be allowed to check deactivation of all exhibited material. We hereby declare that we accept all legal obligations and consequences arising from inadequate deactivation of exhibited military material.

Place Date 2018

.....
Signature of authorized representative

To be filled in by the FF18 representative.

The above listed exhibitor has met all the obligations required by the organizer and may take part in the **Future Forces Exhibition 2018.**

Signature and stamp:

LICENCES - INFORMATION FOR MILITARY AND SECURITY MATERIAL EXHIBITOR

LIST OF EXHIBITS

Please **FILL IN THOROUGHLY** including the Customs Classification – Harmonized Code of exhibiting items.

Item No.	Customs Classification – Harmonized Code	Exhibit Name	Type No.	Production No.	Quantity	Unit Price in EUR (*)	Exhibit Type (A, B, C, D) and Purpose of Use (1, 2, 3)
1	2	3	4	5	6	7	8
Total							

(*) For customs and insurance purpose only

We herewith confirm the completeness, accuracy and truthfulness of all information provided above and we are aware of possible legal consequences arising from the provision of false or otherwise distorted information. Upon the request of competent authorities of the Czech Republic in charge of import/export of material of military nature, we will provide additional information necessary for the issuance of the export/import license.

Information about any changes in the above list of exhibits will be provided to the organizer of the Future Forces Exhibition 2018 in written form. We are aware that any changes in the above mentioned list might be made only with a prior consent by competent authorities of the Czech Republic in charge of import/export of material of military nature and without their approval we will not import any other items that are not included in the list of exhibits to the Czech Republic.

Place

Date

2018

.....

Signature of authorized representative



GENERAL CARGO SHIPPING INSTRUCTIONS

1. EXHIBITION SCHEDULE

Assembly period:	14 - 16 October	08.00 - 20.00
Exhibition dates:	17 - 19 October	
Dismantling period:	19 October	16.00 - 24.00
	20 October	08.00 - 24.00

Delivery to the exhibition ground is allowed during the official build-up days and times which are confirmed by the organiser. Goods that arrive before or after these build-up official days and times will be always unloaded to our warehouse.

2. ROAD-FREIGHT

All road shipments must be consigned freight pre-paid as follows:

Consignee for CMR:
CENTRUMSPED s.r.o.
c/o FUTURE FORCES 2018, Exhibitor Name, Hall/Stand No.
PVA EXPO PRAHA
Beranovych 667
CZ-190 00 PRAGUE 9
Czech Republic

Notify for CMR:
Mr. Filip Cerveny
Phone: +420 602 501 381
Arrival deadline for NON EU-shipments: 4 working days prior to delivery to the exhibition stand

3. AIR-FREIGHT

All shipments for MAWB must be consigned freight pre-paid as follows:

Consignee:
CENTRUMSPED s.r.o.
Vystaviste 416
CZ-170 00 PRAGUE 7
Czech Republic

Notify:
Mr. Filip Cerveny
Tel.: +420 602 501 381, Email: cerveny@centrumsped.cz
c/o FUTURE FORCES 2018

Accompanying documentation Pro-forma invoice and Packing list have to be addressed as follows:

FUTURE FORCES 2018, Exhibitor Name, Hall/Stand No.
PVA EXPO PRAHA
Beranovych 667
CZ-190 00 PRAGUE 9
Czech Republic
c/o CENTRUMSPED s.r.o.

Airport of destination: PRG / PRAHA – RUZYNE CZECH REPUBLIC
Arrival deadline: 5 working days prior to delivery to the exhibition stand

Any consignment delivered to Praha - Ruzyně Airport will be handled through the CENTRUMSPED warehouse. We cannot guarantee the date of delivery to the exhibition stand for any consignment received after the above-stated deadline.

4. SEA-FREIGHT

All shipments for B/L must be consigned freight pre-paid as follows:

Consignee:
CENTRUMSPED s.r.o.
Vystaviste 416
CZ - 170 00 PRAGUE 7
Notify:
Mr. Filip Cerveny
Tel.: +420 602 501 381, Email: cerveny@centrumsped.cz
c/o FUTURE FORCES 2018

Accompanying documentation Pro-forma invoice and Packing list have to be addressed as follows:

FUTURE FORCES 2018, Exhibitor Name, Hall/Stand No.
PVA EXPO PRAHA

Beranovych 667
CZ-190 00 PRAGUE 9
Czech Republic
c/o CENTRUMSPED s.r.o.

It's highly recommended to use Seaway bill or Express B/L.

Seaport of destination: HAMBURG or BREMERHAVEN / Germany

Arrival deadline: LCL: 15 working days prior to delivery to the exhibition stand
FCL: 10 working days prior to delivery to the exhibition stand

All consignments delivered to the Hamburg or Bremerhaven Seaport will be handled through the CENTRUMSPED warehouse. We cannot guarantee the date of delivery to the exhibition stand for any consignments received after the above-stated deadline.

5. DOCUMENTS

Separated Pro-forma invoices for TEMPORARY INBOUND or PERMANENT INBOUND and Packing lists have to be addressed as follows:

FUTURE FORCES 2018 Prague, Exhibitor Name, Hall/Stand No.
PVA EXPO PRAHA
Beranovych 667
CZ-190 00 PRAGUE 9
Czech Republic
c/o **CENTRUMSPED s.r.o.**

To ensure any inconvenience to customs clearance on arrival, it is imperative that the drafts of the accompanying documents must be forwarded to us for double checking well in advance to the arrival of shipments in Czech Republic to Centrumsped:

Road-freight: at least 2 working days prior to truck departure from Origin
Air-freight: at least 3 working days prior to departure of shipment from Origin
Sea-freight: at least 5 working days prior to departure of vessel from Origin
ATTN: Email: cerveny@centrumsped.cz

6. PRE-ALERTS

All shipments have to pre-alerted in day of their departure from origin by e-mail.

ATTN: Email: cerveny@centrumsped.cz

7. LABELING OF PACKAGES

All cases, packing materials etc. have to be legibly identified by the exhibitor (identification of the exhibition, name of the exhibitor, stand number and exhibition hall number) with a label, which he will receive from the forwarding agent.

FUTURE FORCES 2018 Prague, Exhibitor Name, Hall/Stand No.
c/o CENTRUMSPED s.r.o.
PVA EXPO PRAHA
Beranovych 667
CZ-190 00 PRAGUE 9
Czech Republic
Dimensions: X X cm
Gross Weight:kg
Net Weight: Kg

8. CUSTOMS PROCEDURE (NON EU-SHIPMENTS)

The customs clearance and inspection of all non-EU consignments shall be affected exclusively by CENTRUMSPED.

- exhibits, exhibition materials (merchandise for temporary use): pro-forma invoice (at least 2 originals) with exact consignment details (means gross/net weight, number of freight pieces, number of particular pieces, price, delivery terms - according to INCOTERMS, Brussels – customs code).
- for merchandise, which is being imported only for the exhibition purposes and for which is its sale during the exhibition not expected and it is obvious, that will be in a unchanged form returned back abroad, we recommend to use Carnet ATA as the accompanying customs document (from the Chamber of Commerce and Industry in the country of origin).
- advertising, consumer materials (advertising printouts – catalogues etc., advertising gifts, consumer goods - refreshments (merchandise for consumption): for these goods a special pro-forma invoice has to be available (requirements above), because this merchandise is according to the valid customs regulations after arrival identified for release into free circulation,

or for consumption during the exposition, and customs fees (duty, VAT, or Consumer tax) are attached to this merchandise.

- Import of the alcohol, tobacco, weapons and dangerous products is strictly prohibited

Consignee for T1 Form: CENTRUMSPED s.r.o.
 Beranovych 667
 CZ-190 00 PRAGUE

Customs Office for T1 Form: CZ510201

As for the non-EU consignments (exhibits) delivered from abroad it is necessary to take into account 1-2 working days for the customs clearance procedure as the customs authority works only within working days Monday – Friday, 8.00 – 13.00

9. STORAGE OF EMPTIES

The empty boxes of your material and exhibits will be delivered into a warehouse, stored during the whole time period of the exhibition and after termination of the exhibition will be brought back to your stands. Empty cases are cases, pallets, baskets, barrels, etc. without exhibits, any of their parts, or without any exhibition materials for which is forwarder not liable during the storage period, if storage of such a material is not properly ordered!

10. WARNING

In case of import of non-declared goods, CENTRUMSPED doesn't carry any responsibility against the local customs office. All the costs (Penalty, fee, duty, tax etc...) caused by non-declared import must be paid by sender and it is possible that customs office can confiscate the whole delivery (including the properly declared part). This might cause delay of the date of delivery.

11. INSURANCE

Please take into consideration that the liability of CENTRUMSPED Ltd. is limited. We cannot be held responsible for goods left unattended at your stand. We therefore advise that all exhibitors are obliged to insure their goods for the assembly, duration and disassembly. The forwarding agent's responsibility ends at the moment of the goods delivery to the exhibition stand or to the closest possible accessible location, and will be resumed at the moment of collection of the packed and properly marked consignment from the exhibition stand.

12. WOOD PACKING MATERIAL

All wooden packing materials entering any EU port must conform to the international phytosanitary standards set out under ISPM15. In short this means:

Only wood, free of bark, correctly treated and showing the IPPC stamp can enter the European Community.

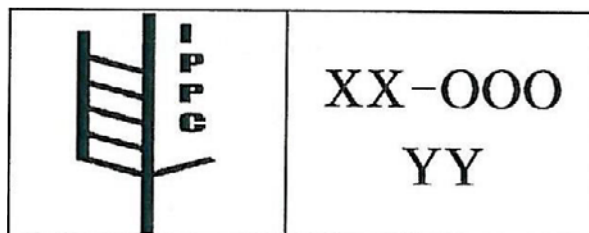

13. CONTACTS

CENTRUMSPED, s.r.o.
www.centrumsped.cz

Mr. Filip Cerveny – Exhibition Co-ordinator
Email: cerveny@centrumsped.cz
Mobile: +420 602 501 381

Mrs. Zuzana Sandova – International Operations Manager
Email: sandova@centrumsped.cz
Phone: +420 547 423 165

Mr. Tomas Dospisil – Managing Director
Email: dospisil@centrumsped.cz
Phone: +420 547 423 166



CONTACTS

Organiser	Progres Partners Advertising s.r.o. Opletalova 55, 110 00 Praha 1			
Contact Persons for Exhibitors	Mr. André Massoud Ms. Marcela Marková	Sales Manager Exhibition Manager	+420 277 010 667 +420 731 117 912 +420 277 010 664	andre@future-forces-forum.org marcela@future-forces-forum.org
Official Expert Events Programme	Mrs. Lucie Vildová	Programme Manager	+420 602 221 864	lucie@future-forces-forum.org
Marketing, Media & PR	Mrs. Olga Pešková	Media & PR Manager	+420 277 010 660	peskova@future-forces-forum.org
Accommodation	Mrs. Pavla Šebestová	Forum Coordinator Manager	+420 224 236 506	pavla@future-forces-forum.org
Armourer	Mr. Tomáš Mazúch Mr. Vladimír Maršík	Armourer Deputy Armourer	+420 608 432 224 +420 602 742 346	tomas.mazuch@perunarms.cz armourer48@gmail.com

Forwarding Services	CENTRUMSPED s.r.o. PVA EXPO PRAHA Beranových 667 190 00 Praha 9			
Contact Persons	Tomáš Dospíšil Zuzana Šandová		+420 547 423 186 +420 547 423 185	dospisil@centrumsped.cz sandova@centrumsped.cz
On-site services	Filip Červený		+420 602 501 381	cerveny@centrumsped.cz

Emergency Telephone Numbers

EUROPEAN EMERGENCY NUMBER	112	Bechyňská 639, Praha 9 – Letňany
POLICE	158	
FIRE RESCUE SERVICE	150	
AMBULANCE	158	
MUNICIPAL POLICE	156	
LOCAL POLICE STATION	+420 286 293 252 ; +420 286 923 184	



ORDER FORMS

Promotion options	19
Offer of exhibition stands	22
Stand construction & layout	23
Extra stand equipment	24
Carpet sampler	27
Floral stand decoration	28
Graphics, digital printing & promotional materials	29
Technical mains & services	30
Catalogue entry	31
Product & service index	32
Advertising in catalogue	34
Confirmation of own stand construction	35



PROMOTION OPTIONS

EXHIBITOR

COMPANY PRESENTATION/LIVE DEMO/POSTER PRESENTATION WITHIN EXPERT EVENTS

<input type="checkbox"/> MESAS 2018 - Modelling & Simulation for Autonomous Systems Conference	1 000 EUR		presentation
	440 EUR		poster
<input type="checkbox"/> Workshop on Applied Modelling and Simulation (WAMS)	1 000 EUR		presentation
	440 EUR		poster
<input type="checkbox"/> Integration of the Exoskeleton in the Battlefield Workshop	1 000 EUR		presentation
	440 EUR		poster
<input type="checkbox"/> Future Forces Individual Systems Congress (FFISC) - International Industry Day	1 000 EUR		presentation
	440 EUR		poster
<input type="checkbox"/> World CBRN & MEDICAL Congress (CEBIRAM)	1 000 EUR		presentation
	440 EUR		poster
<input type="checkbox"/> Multi-domain Advanced Robotic Systems (MARS) Conference	1 000 EUR		presentation
	440 EUR		poster
<input type="checkbox"/> Logistics Capability Conference (LCC)	1 000 EUR		presentation
	440 EUR		poster
<input type="checkbox"/> Geospatial, Hydrometeorological and GNSS Conference (GEOMETOC)	1 000 EUR		presentation
	440 EUR		poster
<input type="checkbox"/> Future of Cyber Conference - Smart Cyber Defence Workshops & Live Hacking Zone	Table-top presentation 1200 EUR		presentation
	Workshop Slot 1200 EUR		one slot
	800 EUR		other slots
	Live Hacking Zone presentation 1000 EUR		presentation
<input type="checkbox"/> Biometrics Conference	Partner Slot 1500 EUR		presentation
	Table-top Presentation 1200 EUR		presentation

ADMISSION TO RESTRICTED AREAS

<input type="checkbox"/> VIP Lounge	180 EUR		pc/pcs
<input type="checkbox"/> Official Party for VIPs, exhibitor and partners – Hangar party	50 EUR		pc/pcs



PROMOTION OPTIONS

EXHIBITOR

PARTNERSHIP OPTIONS

As a partner you will receive exclusive marketing/PR support, visibility and targeted services.
Please contact us in case of any enquiry - info@future-forces-forum.org

PARTNERSHIP - FUTURE FORCES FORUM

<input type="checkbox"/>	General Partner	40 000 EUR		pc
<input type="checkbox"/>	Main Partner	28 000 EUR		pc/pcs
<input type="checkbox"/>	Partner	16 000 EUR		pc/pcs

PARTNERSHIP - FUTURE FORCES EXHIBITION

<input type="checkbox"/>	General Partner	16 000 EUR		pc
<input type="checkbox"/>	Main Partner	12 000 EUR		pc/pcs
<input type="checkbox"/>	Partner	8 000 EUR		pc/pcs

PARTNERSHIP - EXPERT EVENTS

<input type="checkbox"/>	Strategic Partner - price and conditions differ based on type of the event. Please contact us with any enquiry - info@future-forces-forum.org			
<input type="checkbox"/>	General Partner	5 600 EUR		pc/pcs
<input type="checkbox"/>	Main Partner	3 600 EUR		pc/pcs
<input type="checkbox"/>	Partner	2 000 EUR		pc/pcs

PARTNERSHIP - FUTURE OF CYBER CONFERENCE

<input type="checkbox"/>	General Partner	10 000 EUR		pc
<input type="checkbox"/>	Main Partner	5 000 EUR		pc/pcs
<input type="checkbox"/>	Cyber Pavilion Sponsor	4 000 EUR		pc/pcs
<input type="checkbox"/>	Workshop Partner	2 500 EUR		pc/pcs
<input type="checkbox"/>	Cyber Service Partner	1 000 EUR		pc/pcs

PARTNERSHIP - BIOMETRICS CONFERENCE

<input type="checkbox"/>	General Partner	10 000 EUR		pc
<input type="checkbox"/>	Partner	6 000 EUR		pc/pcs
<input type="checkbox"/>	Topic Sponsor	2 500 EUR		pc/pcs
<input type="checkbox"/>	Biometrics Service Partner	1 000 EUR		pc/pcs

VIP LOUNGE SPONSOR

<input type="checkbox"/>	Exclusive Sponsorship	6 000 EUR		pc
--------------------------	-----------------------	-----------	--	----

GALA EVENING SPONSOR

<input type="checkbox"/>	Exclusive sponsorship of Hangar Party for VIPs, official delegates, distinguished guests, partners and exhibitors	8 000 EUR		pc
--------------------------	---	-----------	--	----



PROMOTION OPTIONS

EXHIBITOR

MEETING ROOMS

<input type="checkbox"/>	Business meeting room incl. snacks and soft drinks - 1 hour	160 EUR	hour/s
--------------------------	---	---------	--------

WEBSITE

<input checked="" type="checkbox"/>	PR article in the News section at www.natoexhibition.org , www.future-forces-forum.org , and social networks	FREE OF CHARGE	
<input checked="" type="checkbox"/>	On-line profile in exhibitor list at www.natoexhibition.org + company logo	FREE OF CHARGE	
<input type="checkbox"/>	Homepage online banner at www.natoexhibition.org (285x70 px, 1 year promotion)	600 EUR	pc/pcs
<input type="checkbox"/>	Commercial spot in Media Gallery at www.natoexhibition.org , www.future-forces-forum.org , social networks, and YouTube Channel	300 EUR	pc/pcs

COMPANY LOGO

<input type="checkbox"/>	e-Newsletter Future Forces Forum	480 EUR	pc/pcs
<input type="checkbox"/>	Visitor and VIP Registration Desk	480 EUR	pc/pcs
<input type="checkbox"/>	Event map	120 EUR	pc/pcs

FAIRGROUND

Outdoor advertisement

<input type="checkbox"/>	Billboard - Fairground area (5.2 x 2.4 m)	1 450 EUR	pc/pcs
<input type="checkbox"/>	Banner - Exhibition Hall Entrance (3.0 x 1.0 m)	650 EUR	pc/pcs
<input type="checkbox"/>	Billboard - Main entrance to fairgrounds	2 000 EUR	pc/pcs

Indoor advertisement

<input type="checkbox"/>	Roll-up banner or panel with graphics (up to 2.0 x 1.0 m) - Business Centre	620 EUR	pc/pcs
<input type="checkbox"/>	Roll-up banner or panel with graphics (up to 2.0 x 1.0 m) - Exhibition Halls	420 EUR	pc/pcs
<input type="checkbox"/>	Roll-up banner or panel with graphics (up to 2.0 x 1.0 m) - Entrance to exhibition halls	420 EUR	pc/pcs
<input type="checkbox"/>	Banner - Official Party for VIPs, partners and exhibitors	600 EUR	pc/pcs
<input type="checkbox"/>	Roll-up banner or panel with graphics (up to 2.0 x 1.0 m) - Relax Zone	300 EUR	pc/pcs
<input type="checkbox"/>	Roll-up banner or panel with graphics (up to 2.0 x 1.0 m) - VIP Lounge	800 EUR	pc/pcs
<input type="checkbox"/>	Company spot - Exhibition halls & VIP Lounge	800 EUR	pc/pcs
<input type="checkbox"/>	Company leaflets at distribution points (visitor registration desk, VIP registration desk, information desk, VIP Lounge, exhibition halls)	320 EUR	pc/pcs
<input type="checkbox"/>	Show bags for visitors and VIP delegations	3 000 EUR	pc



OFFER OF EXHIBITION STANDS

The following types of expositions can be ordered for any type of indoor exhibit space.

BASIC

Price: 38 EUR/m²

Basic shell scheme includes:

White walls with aluminium frame, grey carpet, an information counter, a table with 4 chairs, name board

Not included:

Technical connections (power supply, water and sewage, internet), graphics on the walls, additional furniture, equipment and services (cleaning, catering, etc.)



PREMIUM

Price: 58 EUR/m²

Premium shell scheme includes:

White walls with aluminium frame, carpet in a colour of your choice, an information counter, a table with 4 chairs, a bar stool, lockable storage (1x1 m), rack, spotlights (1x 100 W per 3 m²), name board

Stand area from 20 m²:

Lockable storage 1x1,5 m

Not included:

Technical connections (power supply, water and sewage, internet), graphics on the walls, additional furniture, equipment and services (cleaning, catering, etc.)



EXCLUSIVE

Price: 120 EUR/m

Exhibition stand construction includes:

Shell scheme lined with white laminated boards to a height 2,5m. The lining completely covers the aluminium frame and the supporting wall elements. A possibility of graphics applications on the stand walls.

Not included:

Carpet, graphics on the walls, technical connections, furniture, equipment and other services.



INDIVIDUAL

Price: Please contact us for quotation at info@future-forces-forum.org

Construction of a tailor-made exposition can be provided per your own layout or our proposal. The costs shall be determined by technical design, applied materials and equipment.





STAND CONSTRUCTION & LAYOUT

EXHIBITOR

.....

EXHIBIT SPACE DETAILS

Our exhibit area is: m x m = m²

Type of exhibit space

<input type="checkbox"/> 1 side open (Row)	<input type="checkbox"/> 3 sides open (Peninsula)
<input type="checkbox"/> 2 sides open (Corner)	<input type="checkbox"/> 4 sides open (Island)

EXHIBITION STAND CONSTRUCTION

BASIC
 PREMIUM
 EXCLUSIVE
 INDIVIDUAL

REQUIRED TEXT TO IDENTIFY THE STAND

NAME BOARD:

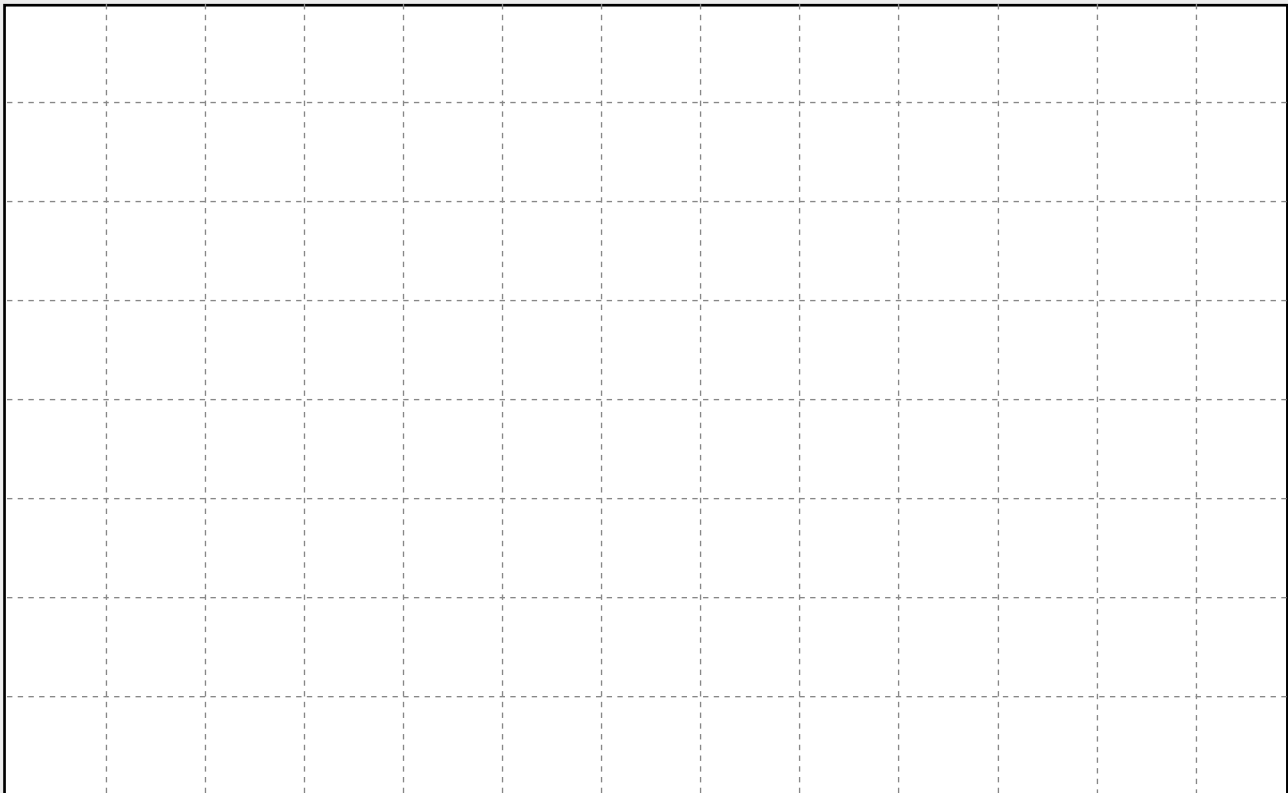

- | | | | |
|---------------------|----------------|-------------------|----------------------|
| Partition wall | Table showcase | Shelf | 24-hour power supply |
| Name board | Square table | Leaflet stand | Sink |
| Folding door | Round table | Coat stand | Water supply |
| Hinged door | Bar table | Coat rack (wall) | Refrigerator |
| Information counter | Bar stool | Spotlight | LED TV |
| Glass showcase | Chair | Power socket 230V | |



EXTRA STAND EQUIPMENT

EXHIBITOR

.....

<input type="checkbox"/>	Chrome chair	14 EUR		pc/pcs
<input type="checkbox"/>	Bar stool	22 EUR		pc/pcs
<input type="checkbox"/>	Table - round	26 EUR		pc/pcs
<input type="checkbox"/>	Table - square	26 EUR		pc/pcs

Bar table	36 EUR
	
Order:	pc/s

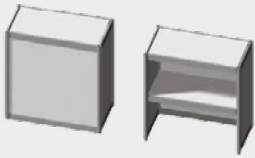
Information counter	48 EUR
	Including open shelf Width: 100 cm Height: 110 cm Depth: 50 cm
Order:	pc/s

Information counter	72 EUR
	Including lockable storage unit Width: 100 cm Height: 110 cm Depth: 50 cm
Order:	pc/s

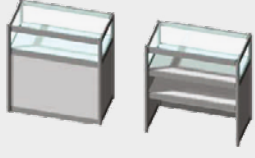
Table showcase	104 EUR
	Including open shelf Width: 100 cm Height: 110 cm Depth: 50 cm
Order:	pc/s

Large showcase	152 EUR
	including lighting and 2 glass shelves Width: 100 cm Height: 250 cm Depth: 50 cm
Order:	pc/s



Small showcase	140 EUR
	including lighting and 2 glass shelves Width: 50 cm Height: 250 cm Depth: 50 cm
Order:	pc/s



EXTRA STAND EQUIPMENT

EXHIBITOR

Pedestal	44 EUR	Wall shelf	10 EUR
	Width: 100 cm Height: 50 cm Depth: 50 cm and more available		Width: 100 cm Depth: 30 cm
Order:	pc/s	Order:	pc/s

Shelf	56 EUR	Leaflet stand	32 EUR
	Width: 100 cm Height: 200 cm Depth: 50 cm		
Order:	pc/s	Order:	pc/s

Wall mounted coat rack	14 EUR	Coat stand	24 EUR
	Width: 100 cm		Height: 200 cm
Order:	pc/s	Order:	pc/s

LCD TV			
	Diagonal: <input type="checkbox"/> 42" 180 EUR <input type="checkbox"/> 50" 220 EUR <input type="checkbox"/> 55" 260 EUR <input type="checkbox"/> 65" 300 EUR <input type="checkbox"/> 82" 1 120 EUR <input type="checkbox"/> 95" 1 560 EUR <input type="checkbox"/> 98" 1 960 EUR <input type="checkbox"/> LED indoor ABSEN A3 400 EUR/m ² price up to 12m ² / without installation <input type="checkbox"/> LED indoor ABSEN A3 320 EUR/m ² price over 12m ² / without installation	Required Input/Output: <input type="checkbox"/> LCD <input type="checkbox"/> HDMI <input type="checkbox"/> USB <input type="checkbox"/> VGA	TV mount: <input type="checkbox"/> Wall mounted <input type="checkbox"/> Table stand <input type="checkbox"/> Floor stand
Order:	pc/s		



SUBMISSION DEADLINE: 17. 08. 2018



Fill out the form using the [tool Add Text](#) in the toolbar
File > Fill & Sign.



EXTRA STAND EQUIPMENT



















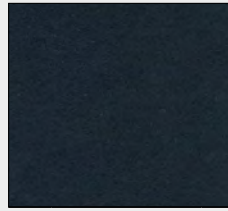
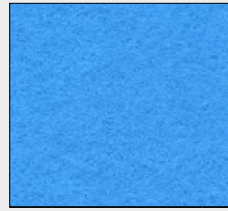

EXHIBITOR			
.....			
<input type="checkbox"/>	DVD player	30 EUR/pc	pc/pcs
<input type="checkbox"/>	Socket	11 EUR/pc	pc/pcs
<input type="checkbox"/>	Spotlight 100 W	18 EUR/pc	pc/pcs
<input type="checkbox"/>	Kettle	16 EUR/pc	pc/pcs
<input type="checkbox"/>	Microwave oven	39 EUR/pc	pc/pcs
<input type="checkbox"/>	Kitchen sink	164 EUR/pc	pc/pcs
<input type="checkbox"/>	Set of dishes for 6 persons	51 EUR/pc	pc/pcs
<input type="checkbox"/>	Refrigerator	79 EUR/pc	pc/pcs
<input type="checkbox"/>	Bin	4 EUR/pc	pc/pcs
<input type="checkbox"/>	Wall cabinet for kitchen (w 97 x h 60 x d 30 cm)	28 EUR/pc	pc/pcs
<input type="checkbox"/>	Wall panel - white 100 x 250 cm	40 EUR/pc	pc/pcs
<input type="checkbox"/>	Wall panel - white 50 x 250 cm	20 EUR/pc	pc/pcs
<input type="checkbox"/>	Wall panel - transparent 50 x 250 cm	36 EUR/pc	pc/pcs
<input type="checkbox"/>	Lockable folding door 100 x 250 cm	92 EUR/pc	pc/pcs
<input type="checkbox"/>	Lockable hinged door 100 x 250 cm	112 EUR/pc	pc/pcs
<input type="checkbox"/>	Carpet incl. laying and disposal after the show (carpet sampler on the next page)	10 EUR/m ²	m ²

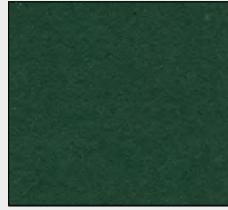

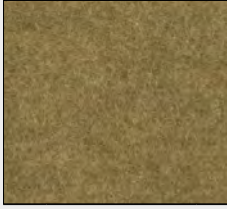
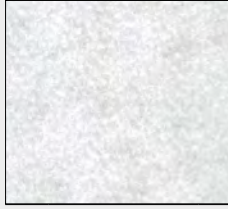
CARPET SAMPLER

EXHIBITOR

.....

		Standard carpet for shell scheme stands 		
<input type="checkbox"/> Black m ²	<input type="checkbox"/> Anthracit m ²	<input type="checkbox"/> Grey m ²	<input type="checkbox"/> Light Grey m ²	<input type="checkbox"/> Red m ²
				
<input type="checkbox"/> Orange m ²	<input type="checkbox"/> Yellow m ²	<input type="checkbox"/> Light Red m ²	<input type="checkbox"/> Navy Blue m ²	<input type="checkbox"/> Light Blue m ²
				
<input type="checkbox"/> Blue m ²	<input type="checkbox"/> Dark Blue m ²	<input type="checkbox"/> Violet m ²	<input type="checkbox"/> Dark Green m ²	<input type="checkbox"/> Light Green m ²
				
<input type="checkbox"/> Beige m ²	<input type="checkbox"/> Light Grey/White m ²	<input type="checkbox"/> Wine Red m ²	<input type="checkbox"/> Red/Black m ²	<input type="checkbox"/> Blue/Black m ²
				
<input type="checkbox"/> White m ²	<input type="checkbox"/> Green/Black m ²			



FLORAL STAND DECORATION

EXHIBITOR

.....

PLANTS IN POTS

<input type="checkbox"/>	up to 15 cm	10 EUR/pc		pc/pcs
<input type="checkbox"/>	approx. 50-60 cm Different kinds depending on current availability, i.e. Zamioculcas, Schefflera actinophylla, Anthurium Scherzerianum, Spathiphyllum, Fatsia Japonica, Orchidaceae, etc	25 EUR/pc		pc/pcs
<input type="checkbox"/>	approx. 100-150 cm Different kinds depending on current availability, i.e. Fikus benjamina, Areca catechu, Yucca aloifolia, etc.	37 EUR/pc		pc/pcs



Zamioculcas



Schefflera actinophylla



Anthurium Scherzerianum



Spathiphyllum



Fatsia Japonica



Fikus benjamina



Areca catechu



Yucca aloifolia



Orchidaceae

TABLE FLOWER DECORATION

<input type="checkbox"/>	Small (Ø 15 cm)	14 EUR/pc		pc/pcs
<input type="checkbox"/>	Medium (Ø 25 cm)	20 EUR/pc		pc/pcs
<input type="checkbox"/>	Large (Ø 35 cm)	26 EUR/pc		pc/pcs
<input type="checkbox"/>	Arrangement for container (150 cm)	100 EUR/pc		pc/pcs



SUBMISSION DEADLINE: 17. 08. 2018



Fill out the form using the [tool Add Text](#) in the toolbar
File > Fill & Sign.



GRAPHICS, DIGITAL PRINTING & PROMOTIONAL MATERIALS

PRINT DATA FOR GRAPHICS MUST BE SUBMITTED TILL 17. 09. 2018

EXHIBITOR

DIGITAL PRINTING ON SELF-ADHESIVE FILM

Make your stand visible with eye-catching large format graphics. We provide comprehensive service including data processing, 3D stand design, printing, application on partition walls and stand furniture including removal.

<input type="checkbox"/>	Name board	14 EUR/m	m
<input type="checkbox"/>	Information counter – front panel	44 EUR/pc	pc/pcs
<input type="checkbox"/>	Information counter – side panel	22 EUR/pc	pc/pcs
<input type="checkbox"/>	Table showcase – front panel	44 EUR/pc	pc/pcs
<input type="checkbox"/>	Table showcase – side panel	22 EUR/pc	pc/pcs
<input type="checkbox"/>	Shell scheme partition wall (1-2 panels)	88 EUR/pc	pc/pcs
<input type="checkbox"/>	Shell scheme partition wall (3 and more panels)	70 EUR/pc	pcs
<input type="checkbox"/>	Exclusive shell scheme lining (laminated boards)	40 EUR/m ²	m ²

DIMENSIONS FOR PRINT DATA	TRIM SIZE (mm)	BLEED SIZE
Shell scheme wall panel	w 964 x h 2280	+ 5 mm each side
Information counter - front panel	w 964 x h 1014	+ 5 mm each side
Information counter - side panel	w 464 x h 1014	+ 5 mm each side
Table showcase - front panel	w 964 x h 715	+ 5 mm each side
Table showcase - side panel	w 464 x h 715	+ 5 mm each side
Name board	h 350	+ 10 mm each side

ROLL-UP BANNERS

Aluminium stand incl. roll-up printed banner. The presentation system is supplied with a canvas carrying bag.

<input type="checkbox"/>	Roll-up banner w 85 x h 200 cm	100 EUR/pc	pc/pcs
<input type="checkbox"/>	Roll-up banner w 100 x h 200 cm	120 EUR/pc	pc/pcs
<input type="checkbox"/>	Roll-up banner w 120 x h 200 cm	145 EUR/pc	pc/pcs
<input type="checkbox"/>	Roll-up banner w 150 x h 200 cm	175 EUR/pc	pc/pcs

PROMOTION MATERIALS

The Future Forces Forum Marketing Team may provide all printing materials for exhibitors / partners (flyers, posters, brochures, catalogues, business cards, etc.), promotional and gift items of all kinds, presentation systems and other custom goods including the possibility of graphic design. Please send your enquiry to marcela@future-forces-forum.org no later than 1 September 2018.



TECHNICAL MAINS & SERVICES

EXHIBITOR

POWER SUPPLY

Exhibit space	
<input type="checkbox"/> Indoor	<input type="checkbox"/> Outdoor

For power input 9 kW or more, it is necessary to use a switch board. Exhibitors can either use their own, or hire it via the Order Form Technical Mains & Services. **Please send the requested layout/position of technical connections within your exposition to Organiser via the Order Form Detailed Stand Drawing & Layout.**

Electric input incl. consumption	Price
<input type="checkbox"/> up to 2 kW	204 EUR
<input type="checkbox"/> up to 5 kW	344 EUR
<input type="checkbox"/> up to 9 kW	444 EUR
<input type="checkbox"/> up to 15 kW	633 EUR
<input type="checkbox"/> up to 21 kW	756 EUR
<input type="checkbox"/> up to 40 kW	1 360 EUR

Night power supply	Price
<input type="checkbox"/> 24h power supply for refrigerators etc.	63 EUR

Type of power supply	
<input type="checkbox"/> 230 V	<input type="checkbox"/> 400 V

Switchboard (mandatory for electric input 9 kW and more)	Price
<input type="checkbox"/> Type 400V/ 16 A	176 EUR
<input type="checkbox"/> Type 400V/ 32 A	

5% surcharge for power supply at outdoor exhibit area.



WATER SUPPLY AND DRAINAGE

	Price
<input type="checkbox"/> Connection, consumption, discharge (pipe 10/8 mm, drainage 40 mm)	290 EUR



INTERNET CONNECTION

	Price
<input type="checkbox"/> LAN connection 10/100	88 EUR
<input type="checkbox"/> Wi-Fi single user access	64 EUR
<input type="checkbox"/> Additional access (LAN or Wi-Fi)	32 EUR <input type="text" value=""/> pc/pcs



STAND CLEANING

	Price
<input type="checkbox"/> Daily from the first day of exhibition	<input type="text" value=""/> m ² 2 EUR/m ²





SUBMISSION DEADLINE: 17. 08. 2018



Fill out the form using the [tool Add Text](#) in the toolbar
File > Fill & Sign.



CATALOGUE ENTRY

Each exhibitor will receive one Exhibition Catalogue free of charge during the on-site registration.

EXHIBITOR

Catalogue entry and listing on the exhibition website is included in the registration fee.

Organisation:			
Address:			
Country:		http://	
Phone:		Fax:	
E-mail:		Contact Person:	
Company profile:			

REPRESENTED COMPANIES AND BRANDS:

CO-EXHIBITOR

Catalogue entry and listing on the exhibition website is included in the registration fee.

Organisation:			
Address:			
Country:		http://	
Phone:		Fax:	
E-mail:		Contact Person:	
Company profile:			

REPRESENTED COMPANIES AND BRANDS:



PRODUCTS & SERVICES INDEX

EXHIBITOR

- 100 Cyber Defence, Command, Control and Communication (C3) System, Electronics, Computers and Software**
- 101 Antennas
- 102 Automatic Test Equipment (ATE) and Diagnostic
- 103 C4ISR
- 104 Data Processing and Evaluation Systems
- 105 Digital Systems and Cryptology
- 106 Electro-Acoustic Observation and Access Control Systems
- 107 Electronic Warfare, Intelligence and Communication Systems
- 108 Electro-Optical Systems and Products, Light Signals, Laser Equipment, Flash Lights
- 109 Encrypted Transformations
- 110 Fibre-Optic Materials, Line and Power Distribution Equipment
- 111 Hybrid Technologies and Fuel Cells
- 112 Information Transforming
- 113 Internet, Network Security and Anti-Virus Software
- 114 Laptops
- 115 Manoeuvre and Logistic Software
- 116 Meeting and Training Halls Electronic Systems
- 117 Military Space Systems
- 118 Mobiles
- 119 Navigation Systems (GPS, GNSS)
- 120 Photographical Equipment
- 121 Port, Underwater, Air and Road Observation Systems
- 122 Power Source and Generators
- 123 Radar Systems
- 124 Satellite Communications
- 125 Secured Systems
- 126 Sonar Systems
- 127 Special Training Software, Simulators
- 128 Strategic Communication Systems
- 129 Tactical Communication Systems
- 130 Tactical Communication Centres
- 131 Target Detection Systems
- 132 Transmitters
- 133 Electronic Shielding Devices
- 199 Other
- 200 Identification Friend or Foe (IFF) Systems**
- 201 Automatic Target Recognition
- 202 Challenge – Response Authentication
- 203 Transponder, Transverters, Repeaters
- 204 Secondary Radar Surveillance
- 299 Other
- 300 CBRN Systems**
- 301 Air Conditioning
- 302 CBRN Detection and Decontamination Systems
- 303 Filtration Units
- 304 Simulation and training
- 399 Other
- 400 Weapons**
- 401 Anti-Tank Weapons
- 402 Large Caliber Weapons
- 403 Sniper Rifles
- 404 Mortars
- 405 Non-lethal Weapons (Pepper Spray, Tear and Sleep Gas, Psychochemical Weapons, Electroshock Weapons, Electromagnetic Weapons, Water Cannons, etc.)
- 406 Small Arms and Light Weapons (Revolvers, Pistols, Submachine Guns, Carbines, Assault Rifles, Battle Rifles, Multiple Barrel Firearms, Squad Automatic Weapons, Lightmachine Guns, Handgrenades, Medium Machine Guns, Grenade Launchers)
- 407 All Crew – Portable Direct Fire Weapons of Calibre less than 50 mm
- 499 Other
- 500 Ammunition**
- 501 Explosives
- 502 Small-Caliber Ammunition
- 503 Large-Caliber Ammunition
- 504 Mines
- 505 Pyrotechnics
- 506 Rockets and Guided Missiles
- 507 Rubber, Plastic and Wax Bullets
- 599 Other
- 600 Bomb Disposal**
- 601 Bomb Squad
- 602 Explosive Ordnance Disposal (EOD)
- 603 Improvised Explosive Device Disposal (IEDD)
- 604 Landmine Locating and Mine Clearance Systems
- 605 Laser Ordnance Neutralisation Systems
- 606 Public Safety Bomb Disposal (ESBD)
- 607 Remotely Operated Vehicles
- 608 Unexploded Ordnance (UXO)
- 609 Training Quarrying or Mining/Demining, Old or Unstable Fireworks and Ammunition
- 699 Other
- 700 Vehicles**
- 701 Armed Robotic Vehicles
- 702 Combat Vehicles
- 703 Command Control Vehicles
- 704 Engineering Vehicles
- 705 Military Ambulance Vehicles
- 706 Miscellaneous Transport Vehicles: Trucks, Vans, Tow Vehicles
- 707 Passenger Vehicles
- 708 Support Vehicles
- 709 Tactical Vehicles
- 710 Tactical vehicles CBRN
- 711 Armored Protection
- 799 Other
- 800 Aircrafts**
- 801 Airplanes
- 802 Helicopters
- 803 Electric and electrotechnic aircraft equipment
- 804 Aircraft armament and munitions
- 805 Aviation engines
- 806 Simulation and training
- 808 Armoured Protection
- 849 Other
- 850 Unmanned and Autonomous Systems, Robotics
- 851 Unmanned Air Vehicles (UAV)
- 852 Unmanned Ground Vehicles (UGV)
- 853 Unmanned Surface Vehicles (USV)
- 854 Unmanned Underwater Vessels (UUV)
- 855 Robotics
- 899 Other
- 900 Oil and Petrol Lubricants**
- 901 Mineral Oil
- 902 Organic Oil
- 903 Special Surface Painting
- 904 Cosmetics
- 999 Other
- 1000 Obstacles and Obstacle Clearing Equipment**
- 1001 Bridge Layers
- 1002 Ditching Machines
- 1003 Earth-moving Machines
- 1004 Modular Bridging Systems
- 1005 Multipurpose Road Construction Machines
- 1006 Pontoon Equipment Sets
- 1099 Other
- 1100 Global Combat Systems and Products**
- 1200 Logistics Support Units**
- 1250 Humanitarian Supply Chains**
- 1300 Modular Units and Buildings**
- 1301 Air-conditioning and Heating
- 1302 Cleaning Equipment, Dishwashers
- 1303 Construction Contract Companies
- 1304 Construction Materials and Systems (Concrete, Gassed Bricks, Wet Surfaces, Insulation, Paints, Roofings, Modular Walls, etc.)
- 1305 Environmental Companies and Consultancy Services
- 1306 Field Accommodation and Catering Equipment
- 1307 Heating, Ventilation and Cooling (HVAC) Systems
- 1308 Infrastructure Contractors
- 1309 Kitchen, Dining and Recreation Facilities (Industrial Kitchens, Cafeterias, Bakeries)
- 1310 Military Accommodation Units
- 1311 Modular Hospitals
- 1312 Modular Prefabricated Buildings
- 1313 Offices
- 1314 Pool Construction, Equipment and Chemicals
- 1315 Refrigerated Rooms and Storehouses, Freezers
- 1316 Reinforced Units – Protection against High Angle Artillery Fire
- 1317 Sanitary and Ambulation Buildings
- 1318 Steel and Prefab Structures
- 1319 Storage Facilities and Shelters
- 1320 Subcontractor Services
- 1321 Tailor Made Units to Customer Specification and Needs (Laundry Facilities, Sport Facilities, Laboratories etc.)
- 1322 Telecommunication Units
- 1323 Treatment and Recycling Systems
- 1324 Washing and Drying Machines, Dry Cleaning Machines, Irons
- 1325 Wooden and Steel Furniture
- 1399 Other
- 1400 Military Medical Equipment and Systems**
- 1401 Personal Protective Clothing and Equipment
- 1402 Emergency Intervention and Intensive Care Equipment
- 1403 Mobile and Field Hospitals and Equipment
- 1404 Hospital Management Tools, Equipment and Services
- 1405 Medical Supplies and Hospital Equipment
- 1406 Pharmacy



PRODUCTS & SERVICES INDEX

EXHIBITOR

- | | | |
|--|---|---|
| <ul style="list-style-type: none"> <input type="checkbox"/> 1407 Mechanical and Electronic Medical Diagnosis Equipment <input type="checkbox"/> 1409 Operating Equipment and Supplies <input type="checkbox"/> 1410 Orthopedic Equipment and Prosthetics <input type="checkbox"/> 1411 Physiotherapy and Rehabilitation Equipment and Tools <input type="checkbox"/> 1412 Supply Material <input type="checkbox"/> 1413 Surgery Room Equipment <input type="checkbox"/> 1414 Vaccines <input type="checkbox"/> 1499 Other <input type="checkbox"/> 1500 Repair and Modernisation of Technology and Soldierly Material <input type="checkbox"/> 1600 Future Soldier - Personal, Equipment and Protective Material <input type="checkbox"/> 1601 Combat, Utility and Training Clothing <input type="checkbox"/> 1602 Batteries, Batteries Back-Up, Accumulators, Generators <input type="checkbox"/> 1603 Belts <input type="checkbox"/> 1604 Body Armours <input type="checkbox"/> 1605 Bullet-proof Vests, Flak Jackets, Vests <input type="checkbox"/> 1606 Caps <input type="checkbox"/> 1607 Cases <input type="checkbox"/> 1608 Commemorative Coins, Medals, Decorations, Shoulder Patches <input type="checkbox"/> 1609 Decontamination Kits <input type="checkbox"/> 1610 Diving Equipment, Life Jackets <input type="checkbox"/> 1611 Environmental Hazard Textiles <input type="checkbox"/> 1612 Fabrics <input type="checkbox"/> 1613 Flags and Banners <input type="checkbox"/> 1614 Gas Masks <input type="checkbox"/> 1615 Gloves <input type="checkbox"/> 1616 Helmets <input type="checkbox"/> 1617 Home Textiles <input type="checkbox"/> 1618 Hospital Clothing for Technical Usage <input type="checkbox"/> 1619 Knives, Bayonets, Daggers <input type="checkbox"/> 1620 Leather Garments, Belts <input type="checkbox"/> 1621 Military Ski and Ski Poles <input type="checkbox"/> 1622 Non-Woven Fabrics and Products <input type="checkbox"/> 1623 Other Textile Products <input type="checkbox"/> 1624 Personnel Clothing <input type="checkbox"/> 1625 Powdering Gloves <input type="checkbox"/> 1626 Protection against Nuclear, Biological and Chemical Attack <input type="checkbox"/> 1627 Rubber Rafts <input type="checkbox"/> 1628 Rucksacks <input type="checkbox"/> 1629 Combat Boots <input type="checkbox"/> 1630 Sleeping Bags <input type="checkbox"/> 1631 Socks <input type="checkbox"/> 1632 Sportswear, Equipment for Spare Time <input type="checkbox"/> 1633 Survival Kits <input type="checkbox"/> 1634 Tents <input type="checkbox"/> 1635 Trench Coats <input type="checkbox"/> 1636 Underwear <input type="checkbox"/> 1637 Uniforms <input type="checkbox"/> 1638 Watches <input type="checkbox"/> 1639 Water, Heat and Cold Resistant Military Clothing <input type="checkbox"/> 1640 Work Security Clothing <input type="checkbox"/> 1641 Goggles <input type="checkbox"/> 1699 Other <input type="checkbox"/> 1700 Military Optical Devices <input type="checkbox"/> 1701 Binocular and Night Vision Equipment <input type="checkbox"/> 1702 Field-glass <input type="checkbox"/> 1703 Periscopes <input type="checkbox"/> 1704 Range Finders <input type="checkbox"/> 1799 Other | <ul style="list-style-type: none"> <input type="checkbox"/> 1800 Consumption Goods <input type="checkbox"/> 1801 Cleaning Utensils and Chemicals <input type="checkbox"/> 1802 Foodstuffs <input type="checkbox"/> 1803 Nutriment <input type="checkbox"/> 1804 Packaging <input type="checkbox"/> 1899 Other <input type="checkbox"/> 1900 Geospatial Intelligence, Cartography and Map Systems <input type="checkbox"/> 1901 Geography <input type="checkbox"/> 1902 Data Access and Data Structures <input type="checkbox"/> 1903 Imagery and Gridded Data <input type="checkbox"/> 1904 Meteorology <input type="checkbox"/> 1905 Hydro meteorology <input type="checkbox"/> 1906 Global Navigation Satellite System (GNSS) <input type="checkbox"/> 1907 Public Regulated Service <input type="checkbox"/> 1999 Other <input type="checkbox"/> 2000 Technologies <input type="checkbox"/> 2001 Laser Technologies <input type="checkbox"/> 2002 Nano Technologies <input type="checkbox"/> 2099 Other <input type="checkbox"/> 2100 Camouflage Materials <input type="checkbox"/> 2101 E-Camouflage <input type="checkbox"/> 2102 Invisible Camouflage <input type="checkbox"/> 2103 Smoke, Deceptive target <input type="checkbox"/> 2199 Other <input type="checkbox"/> 2200 Training and Simulation Systems <input type="checkbox"/> 2201 Air Traffic Management <input type="checkbox"/> 2203 Cabin Systems <input type="checkbox"/> 2204 Simulators <input type="checkbox"/> 2299 Other <input type="checkbox"/> 2300 Target Acquisition and Tracking Systems <input type="checkbox"/> 2400 Power Packs <input type="checkbox"/> 2401 Hydraulic Power Pack (micro, mini, standard unit) <input type="checkbox"/> 2402 Hydraulic Pumps, Services <input type="checkbox"/> 2499 Other <input type="checkbox"/> 2500 Police and Integrated Emergency Systems <input type="checkbox"/> 2501 Alarm and Signalisation Systems <input type="checkbox"/> 2502 Anti-Terror Equipment <input type="checkbox"/> 2503 Civil Disorder Intervention Equipment (CDIE) <input type="checkbox"/> 2504 Disaster Equipment <input type="checkbox"/> 2505 Explosive and Weapon Detectors <input type="checkbox"/> 2506 Fire Fighting Equipment and Vehicles <input type="checkbox"/> 2507 Hand-held and Fixed Detectors <input type="checkbox"/> 2508 Personnel Protective Equipment (Shields, Truncheons, Helmets, etc.) <input type="checkbox"/> 2509 Rescue Systems <input type="checkbox"/> 2510 Special Fireman Equipment <input type="checkbox"/> 2511 Special Weapons and Equipment <input type="checkbox"/> 2512 X-ray Equipment <input type="checkbox"/> 2599 Other <input type="checkbox"/> 2600 Measurement and Research Equipment <input type="checkbox"/> 2601 Automotive Calibration Equipment <input type="checkbox"/> 2602 Criminology Laboratory <input type="checkbox"/> 2603 Measurement Equipment, Optical Equipment, Test Equipment and Elements <input type="checkbox"/> 2604 Narcotic Analysis Laboratory Equipment and Supplies <input type="checkbox"/> 2605 Liquid and Gas Flow, Liquid Level, Mechanical Movement <input type="checkbox"/> 2606 Physic and Chemistry Laboratory Equipment and Supplies | <ul style="list-style-type: none"> <input type="checkbox"/> 2607 Pressure, Temperature and Humidity Measurement <input type="checkbox"/> 2608 Quality Control, Classification and Calibration Laboratories <input type="checkbox"/> 2699 Other <input type="checkbox"/> 2700 Material Handling Equipment, Workshop Machineries, Tools and Equipment <input type="checkbox"/> 2701 Bolt Cutters and Levers <input type="checkbox"/> 2702 Punches and Hammers <input type="checkbox"/> 2703 Socket, Hive, Pipe and Rim Wrenches <input type="checkbox"/> 2704 Tool Trolleys and Tool Boxes <input type="checkbox"/> 2799 Other <input type="checkbox"/> 2800 Environmental Protection <input type="checkbox"/> 2801 Advance Identification (warning) <input type="checkbox"/> 2802 Air, Water Quality <input type="checkbox"/> 2803 Ecological demilitarization <input type="checkbox"/> 2804 Hazardous Waste Protection <input type="checkbox"/> 2805 Oil, Water, Air and Land Pollution <input type="checkbox"/> 2806 Radiation Protection <input type="checkbox"/> 2807 Water Treatment, Waste Removal, Filtration, Waste Storage and Disposal <input type="checkbox"/> 2899 Other <input type="checkbox"/> 2900 Procurement, National Acquisition System <input type="checkbox"/> 3000 Asset Management <input type="checkbox"/> 3001 Asset Tracking <input type="checkbox"/> 3002 Bar Coding <input type="checkbox"/> 3051 Associations <input type="checkbox"/> 3099 Other <input type="checkbox"/> 3100 Air-field Marking <input type="checkbox"/> 3200 Office Supplies <input type="checkbox"/> 3201 Book, Map and Other Printed Materials <input type="checkbox"/> 3202 Computers, Printers <input type="checkbox"/> 3203 Fax and Photocopying Machines <input type="checkbox"/> 3204 Printing Press Machines <input type="checkbox"/> 3205 Paper Shredders <input type="checkbox"/> 3206 Paper, Stationery <input type="checkbox"/> 3299 Other <input type="checkbox"/> 3300 Personal Management <input type="checkbox"/> 3400 Services <input type="checkbox"/> 3401 Banking and Insurance Services <input type="checkbox"/> 3402 Catering Services <input type="checkbox"/> 3403 Consultancy Services <input type="checkbox"/> 3404 Tourism Services <input type="checkbox"/> 3405 Transport Services <input type="checkbox"/> 3499 Other <input type="checkbox"/> 3500 Associations, Media, Government Authorities, Organisations <input type="checkbox"/> 3501 Associations <input type="checkbox"/> 3502 Media <input type="checkbox"/> 3503 Government Authorities <input type="checkbox"/> 3504 Organisations <input type="checkbox"/> 3505 Universities <input type="checkbox"/> 3599 Other <input type="checkbox"/> 3600 Cyber security and defence |
|--|---|---|



SUBMISSION DEADLINE: 17. 08. 2018



Fill out the form using the [tool Add Text](#) in the toolbar
File > Fill & Sign.



ADVERTISING IN CATALOGUE

Catalogues will be distribute to Official guests / VIP and to all exhibiting companies free of charge.

EXHIBITOR





ADVERTISING OPTIONS

LOGO Your logo published in the exhibitor directory together with company profile. 120 EUR

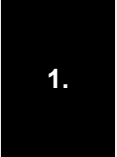
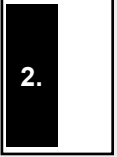
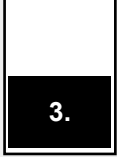

Company logo in EPS / CDR / PDF enclosed to be sent till 17. 08. 2018

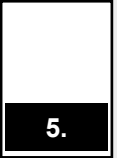
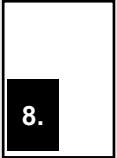
ADVERTISEMENT IN THE CATALOGUE

Advertisement sizes and prices:

 <p>1.</p> <p><input type="checkbox"/> 1/1 page 210 x 297 mm Price: 1100 EUR Quantity: _____</p>	 <p>2.</p> <p><input type="checkbox"/> 1/2 page 90 x 254 mm Price: 660 EUR Quantity: _____</p>	 <p>3.</p> <p><input type="checkbox"/> 1/2 page 185 x 125 mm Price: 660 EUR Quantity: _____</p>	 <p>4.</p> <p><input type="checkbox"/> 1/3 page 59 x 254 mm Price: 468 EUR Quantity: _____</p>
 <p>5.</p> <p><input type="checkbox"/> 1/3 page 185 x 83 mm Price: 468 EUR Quantity: _____</p>	 <p>8.</p> <p><input type="checkbox"/> 1/4 page 90 x 125 mm Price: 340 EUR Quantity: _____</p>	 <p>9. 9.</p> <p><input type="checkbox"/> 2/1 page 2x 210 x 297 mm Price: 2000 EUR Quantity: _____</p>	

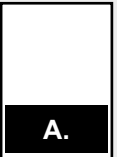
Advertisement sizes and prices on the A4 official catalogue cover:

 <p>A.</p> <p><input type="checkbox"/></p> <p>Front page 1/3 page 185 x 83 mm Price: 1700 EUR</p>	 <p>B.</p> <p><input type="checkbox"/></p> <p>2. / 3. page 1/1 page 210 x 297 mm Price: 1700 EUR</p>	 <p>C.</p> <p><input type="checkbox"/></p> <p>4. page 1/1 page 210 x 297 mm Price: 1700 EUR</p>
---	--	---

Graphic materials: enclosed to be sent till 17. 08. 2018



CONFIRMATION OF OWN STAND CONSTRUCTION

EXHIBITOR

We hereby agree with the technical-safety precautions and binding organisational instructions for exhibitors during the assembly and dismantling of the exposition at Future Forces Exhibition 2018

We accept the full responsibility for the realisation of our exposition and hereby confirm that the contracting company is authorised for stand construction and for implementation of all expert works. All materials used for the stand construction meet standards of flame retardancy.

CONTRACTING COMPANY

Organisation:

Address:

Phone:

E-mail:

Contact Person:

Mobile:

Together with this Confirmation, please send the requested layout/position of the separate technical connections within your exposition to organiser via the Form "Stand Construction Order & Stand Layout" or the original technical drawing from the contracting company.

Structures exceeding the standard permitted height limit (3 m) require authorisation by the exhibition organiser.



Contact Person:

Ms. Marcela Marková

Email:

marcela@future-forces-forum.org

Phone:

+420 778 540 862

Authorized person and position

Signature and date